

Welcome to Our Special Honoring Session

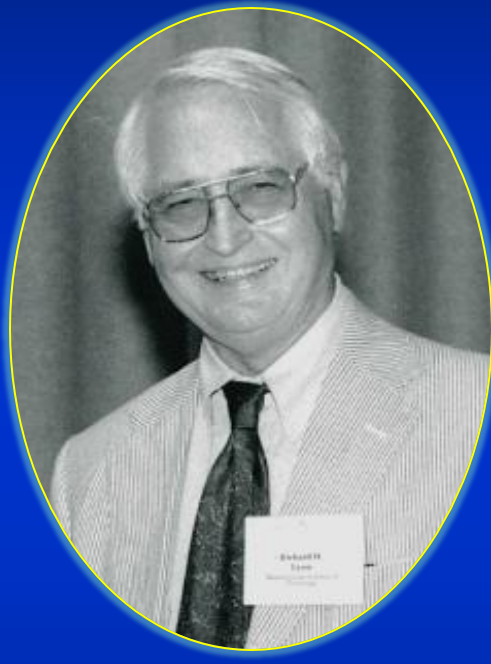

Dick Lyon



Eric Ungar



István Vér

Friends, Colleagues and Gentleman
World Class Noise and Vibration Consultants

Special Session Honoring Richard L. Lyon, Eric E. Ungar and István L. Vér

INCE-USA NoiseCon 2016 Conference

Co Chairs Gladys L. Unger and Eric W. Wood

1:05 – 2:10 Richard Lyon

2:10 – 3:30 Eric Ungar

3:30 – 4:50 István Vér

4:50 – 5:30 Honorees followed by
Social Gathering

Friends and Colleagues

Special Honoring Session Time Schedule

1:00 – 1:05 Session Introduction

Richard H. Lyon

1:05 – 1:10 Introduction

1:10 - 1:25 David Bowen, Group Director Acentech

1:25 – 1:40 Gladys Unger, Senior Consultant Acentech

1:40 – 1:55 Richard De Jong, former SEA colleague

1:55 – 2:10 Kathy Davis, daughter

Eric E. Ungar

2:10 – 2:15 Introduction

2:15 – 2:30 Jeff Zapfe, President Acentech

2:30 – 2:45 Jim Barger, Chief Scientist Raytheon BBN Technologies

2:45 – 3:00 Yoram Kadman, President Kadman-Berman Ltd.

3:00 - 3:15 Hal Amick, Vice President Colin Gordon Associates

3:15 – 3:30 Sharon Lane, daughter

István L. Vér

3:30 – 3:35 Introduction

3:35 – 3:50 Nelson Kiang, Founder and Former Director Eaton-Peabody Laboratory

3:50 – 4:05 Michael Roark, Burns & McDonald

4:05 – 4:20 Kevin Shepherd, Head, Structural Acoustics Branch NASA Langley Research

4:20 – 4:35 Jim Barnes, Principal Consultant Acentech

4:35 – 4:50 Marika Ver

Time for Honorees to Speak followed by Social Gathering with Family and Friends

Dick Lyon Session Schedule

- | | |
|-------------|---|
| 1:05 – 1:10 | Introduction |
| 1:10 – 1:25 | David Bowen, Group Director Acentech |
| 1:25 – 1:40 | Gladys L. Unger, Senior Consultant Acentech |
| 1:40 – 1:55 | Richard De Jong, former SEA colleague |
| 1:55 – 2:10 | Kathy Davis, daughter |

Dick Enjoying Our Tea Party Last Summer



Dick with Two Other Undergrads in the Physics Lab at the University of Evansville early 1950's

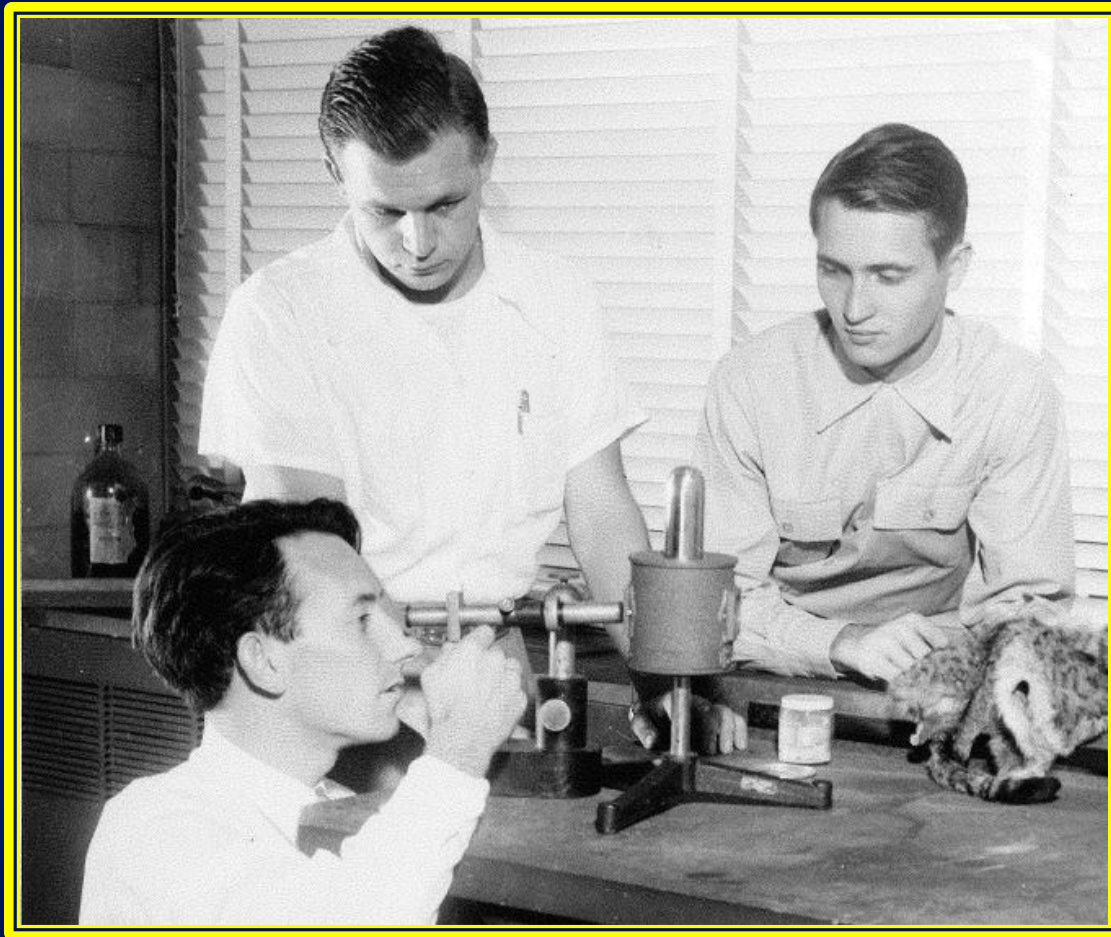

Dick at BBN 1960's



Dick and Jean Enjoying an Evening Together



Dick with Youngsters



Jean and Dick with Lovely Family Members



Slides presented for Dick Lyon by David Bowen,
Principal Consultant and Division Director at Acentech

Some Reflections on My Years with Dick Lyon

David L. Bowen

Director, Noise & Vibration Group

ACENTECH

33 Moulton Street

Cambridge, Mass.

Acoustics AV/IT/Security Vibration

(Just Some of) Dick's Areas of Interest & Contributions

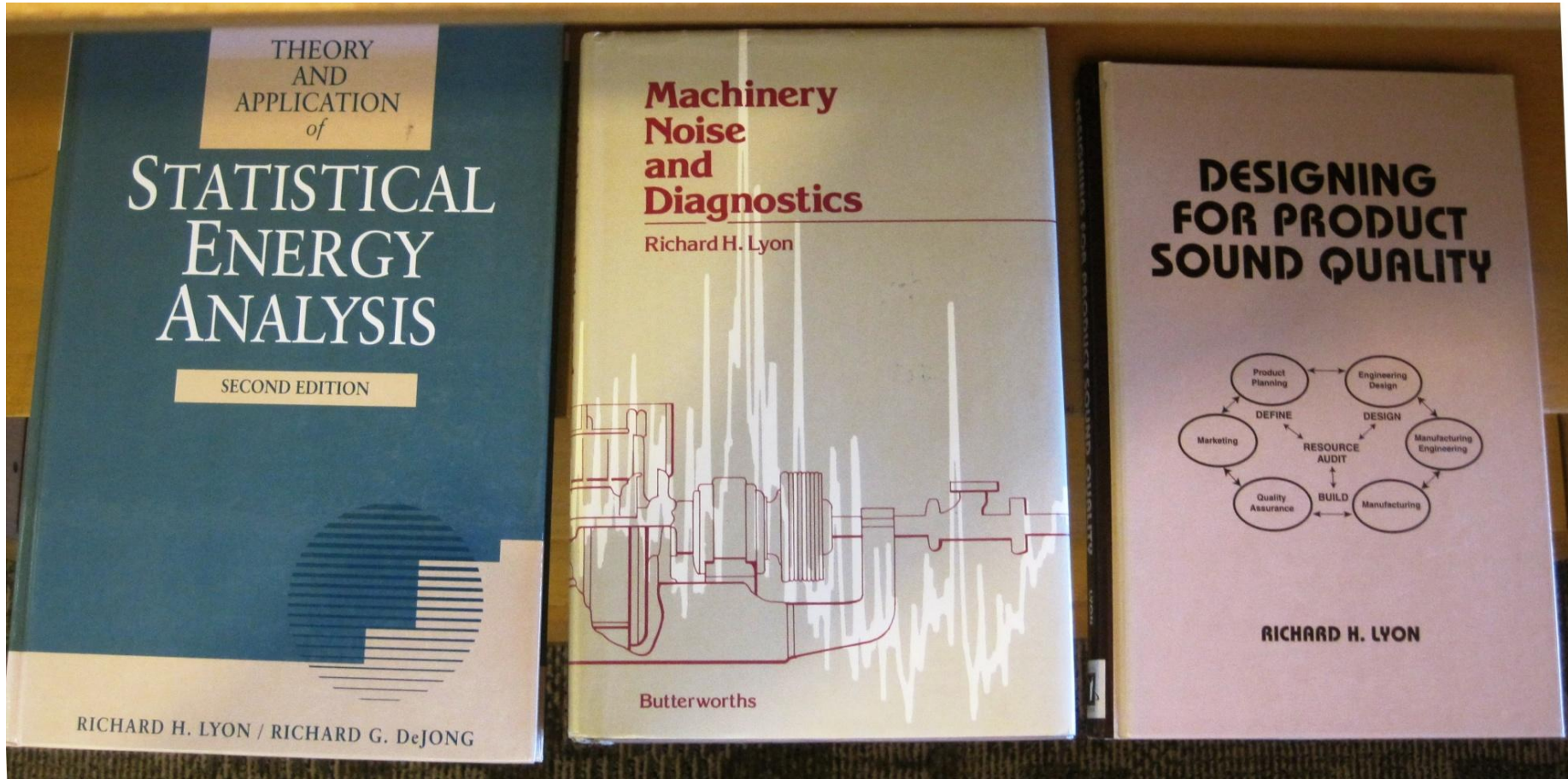

RH Lyon Corp

RH LYON CORP

60 Prentiss Lane
Belmont, Mass. 02178
(617) 484-2931



*Product Design
Diagnostic Systems
Noise and Vibration
Dynamics and Structures*

Diesel Engine Diagnostics

DIESEL ENGINE DIAGNOSTICS PROJECT

Program Goals

1. Obtain reliable pressure and vibration data on diesel engine.
2. Determine variability of pressure and vibration data
 - over data sets
 - different speeds
 - as faults are introduced
3. Recover pressure data from acceleration
 - most effective locations
 - required frequency range
 - inverse filtering procedures
4. Evaluate multiple source recovery
 - overlapping (high rpm) pressures
 - matrix methods
 - others sources (piston slap)

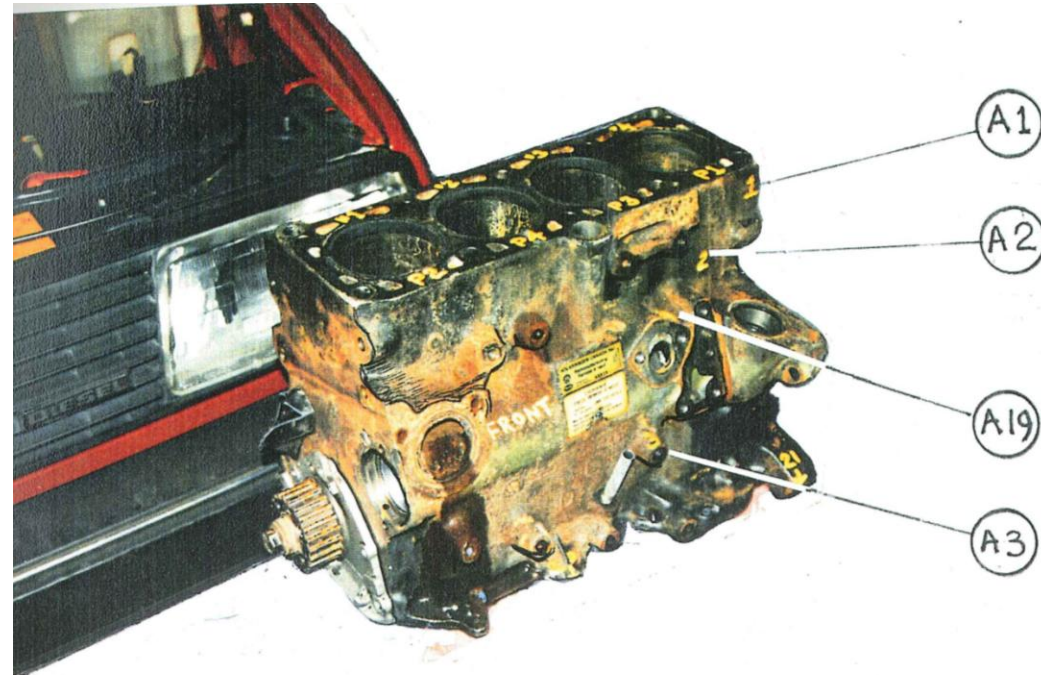

Accelerometer locations on engine block.

Recovery of Cylinder Pressure from Vibration

(using cepstral windowing & inverse filtered engine block vibration)

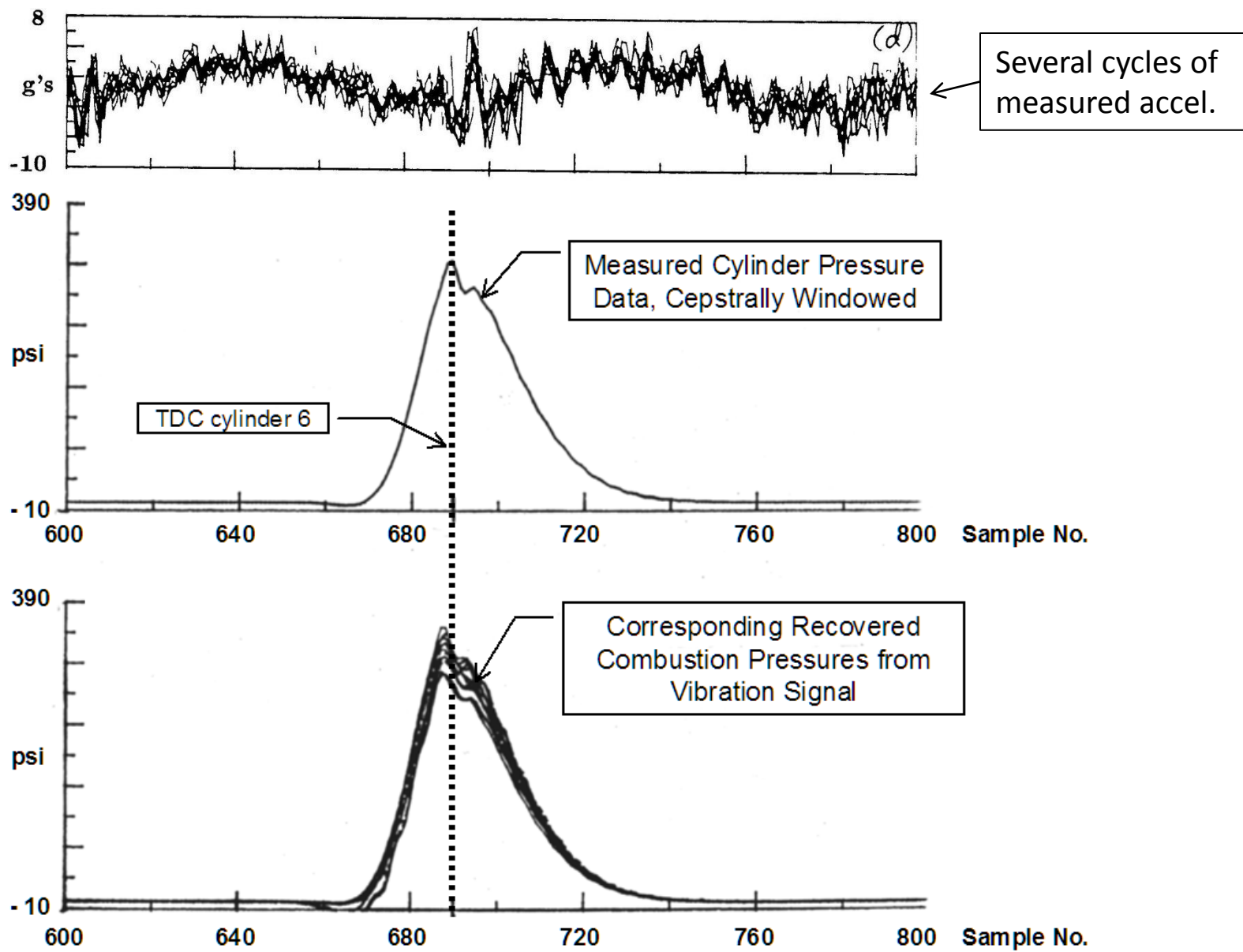

Move to Cambridge

RH Lyon Corp

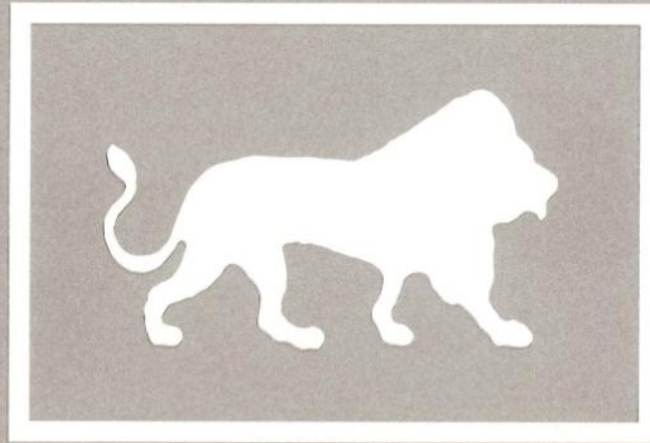

Designing and engineering products
for sound, vibration, and reliability

Diagnostics of Motor-Operated Valves

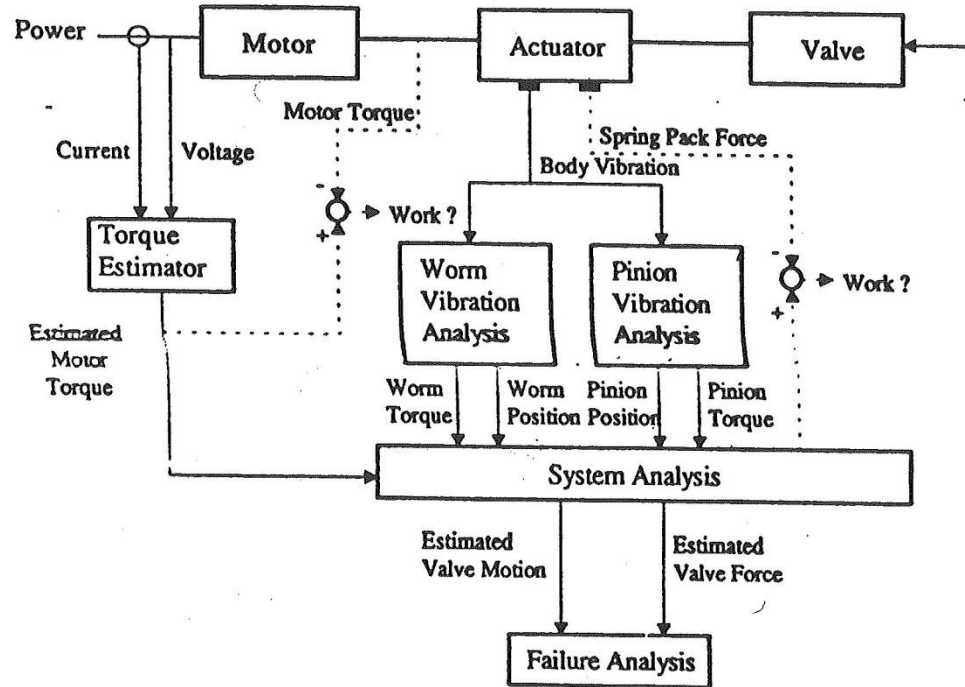

Torque for static close (run D01)

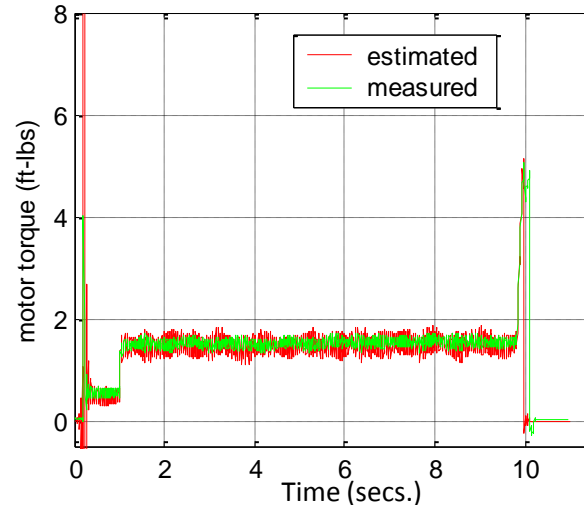

Stem travel for static close (run D04)

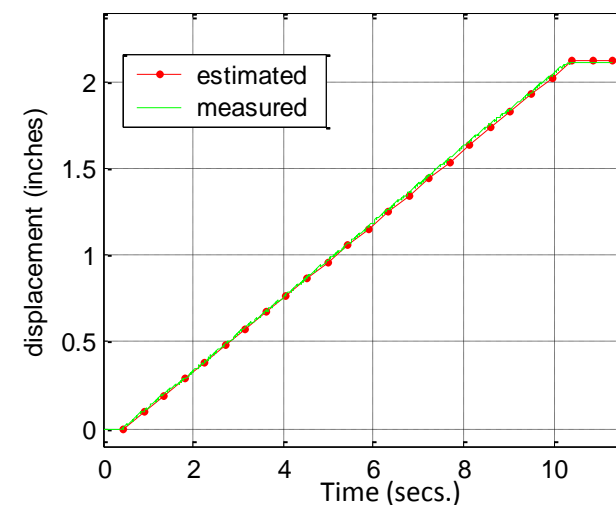

MOVs (con't.)

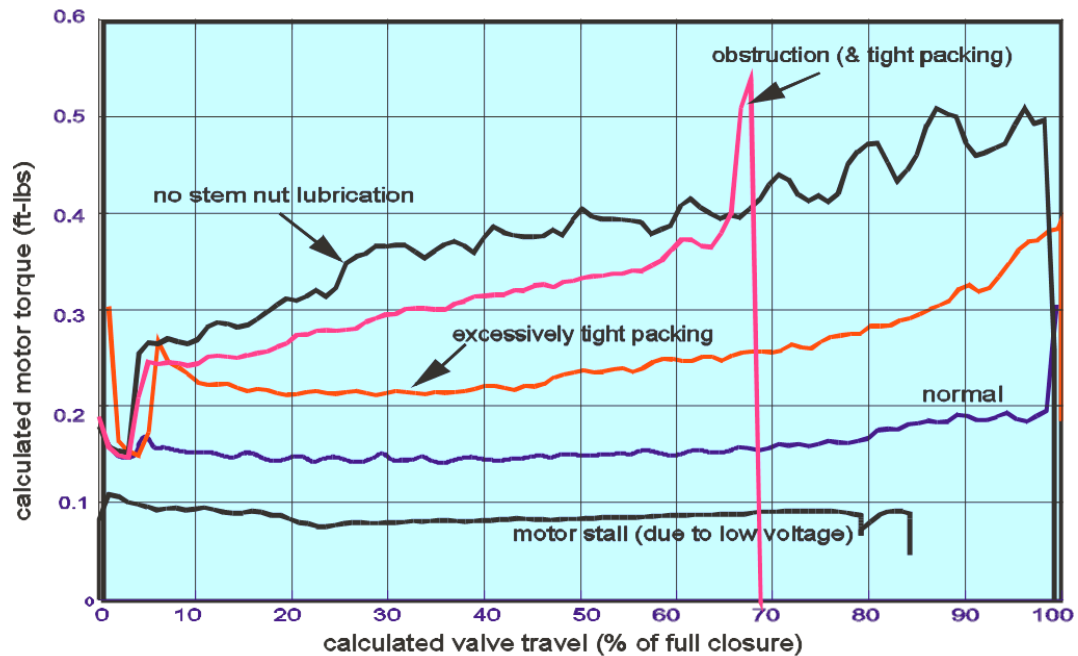
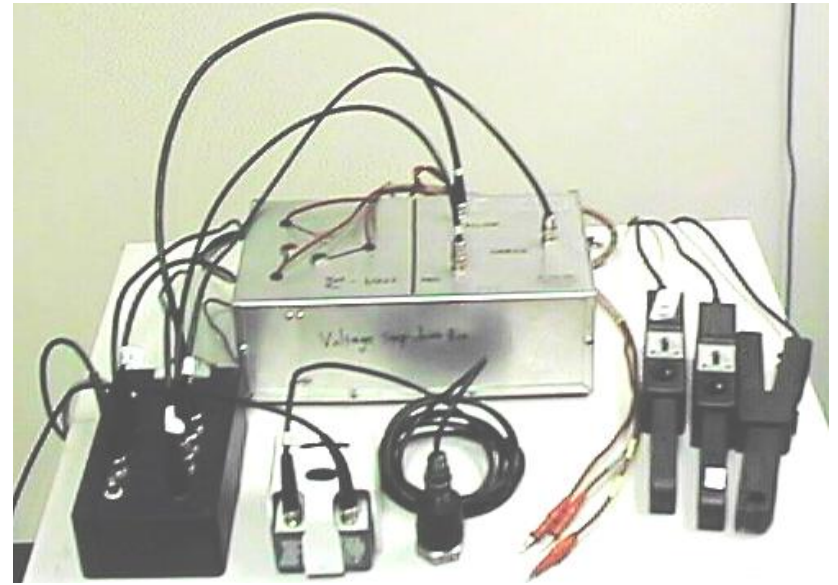
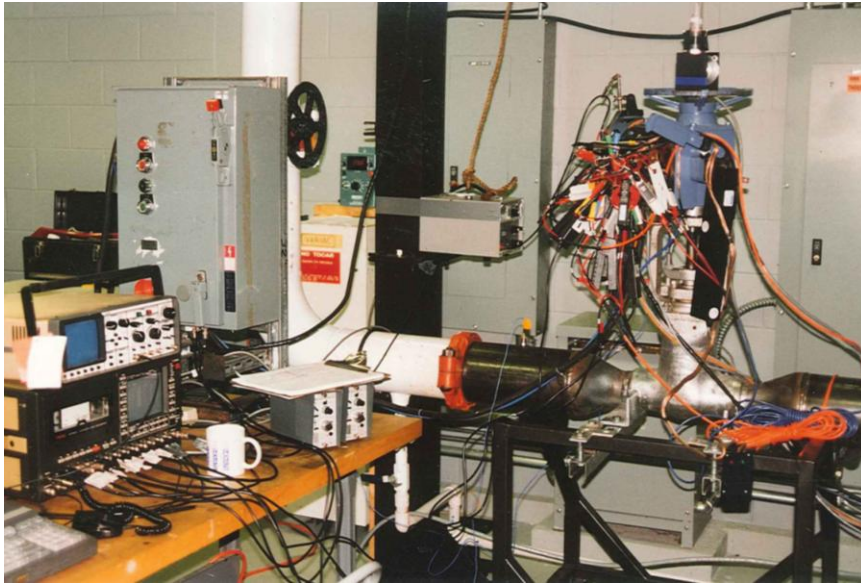

Process Monitoring (Bologna)

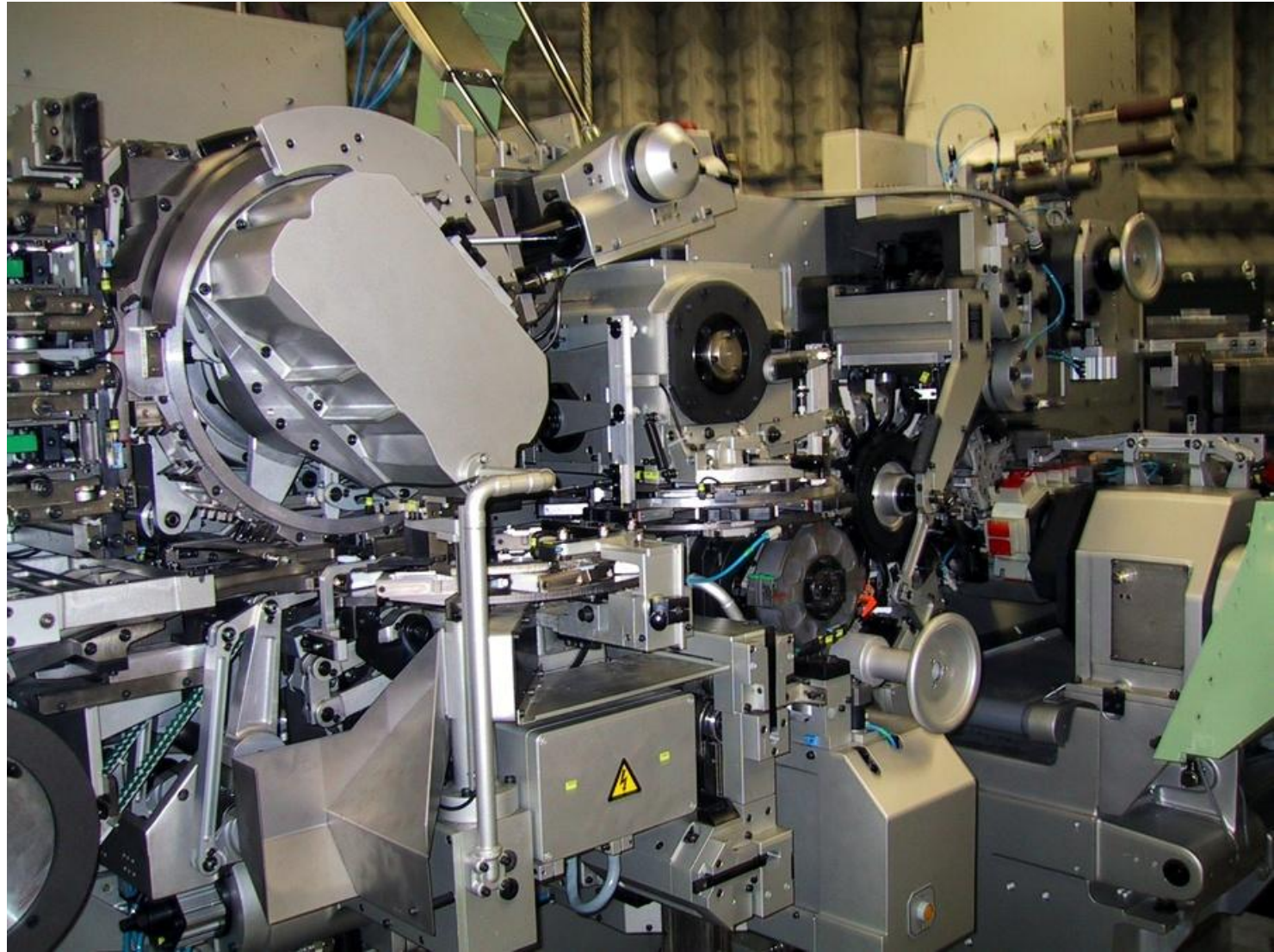

Process Monitoring (con't.)

IDTECT... our know-how is your benefit

THE COMPANY

IDTECT brings you the best expertise world-wide in the field of machine diagnostics, signal processing and statistics.

Together with our partners, decades of expertise are engaged to engineer highly accurate and robust continuous predictive maintenance systems.

THE EXPERIENCE

The technology applies to many different industries and applications including automotive, food & beverage, printing, packaging, metal-working, refrigeration and HVAC.

Our innovative concept is supported by ANVAR, the French Innovation Agency.

REFERENCES

IDTECT systems are installed in various plants throughout Europe. Please contact us for references in your industry.

OUR PARTNERS

RH Lyon Corp., USA. Headed by Prof. Richard Lyon of MIT with over 20 years of experience in machine vibration analysis.

INRIA, France. Leading applied research lab in IT and automation with 3000 scientists.

KXEN, USA. Next generation statistical modelling software with robust predictive capabilities.



Offices in Paris, Milan, Hanover, Geneva and Boston.

Your IDTECT contact



IDTECT SA
22 rue de la Victoire
75009 Paris, France

tel.: +33 1 42 81 82 11
fax: +33 1 42 81 82 21
info@idtect.com - www.idtect.com

TREND DEFINITION

A trend is recognized within a short time and the expected breakdown time is calculated and communicated well in advance.

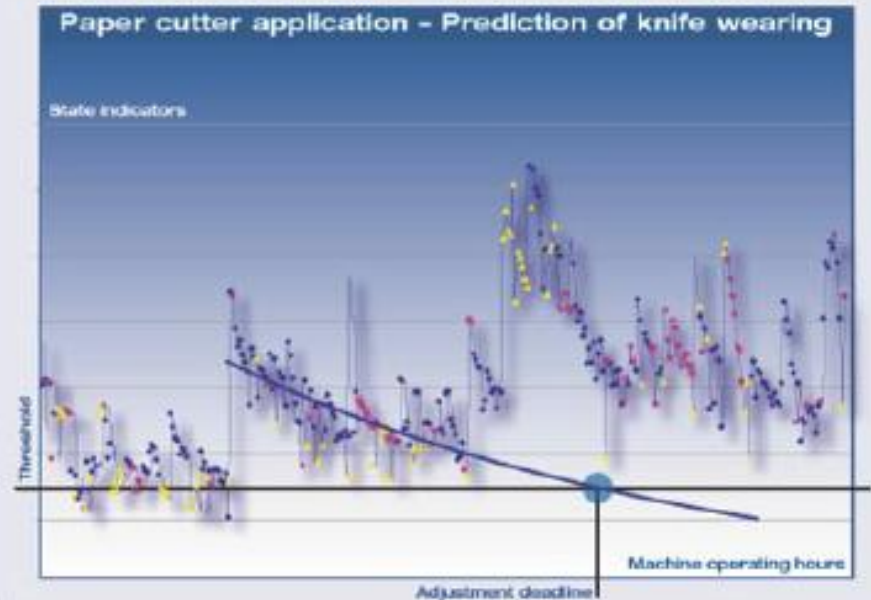

ARTIFICIAL INTELLIGENCE

Today's computing and communication technologies enable to process huge amounts of data and communicate them to a central server in order to be analysed and compared with historical data from one or multiple similar machines located anywhere in the world.

DIFFERENTIATE YOURSELF!

Show your customers that YOU are the technology leader!

Active Control (of Transients)

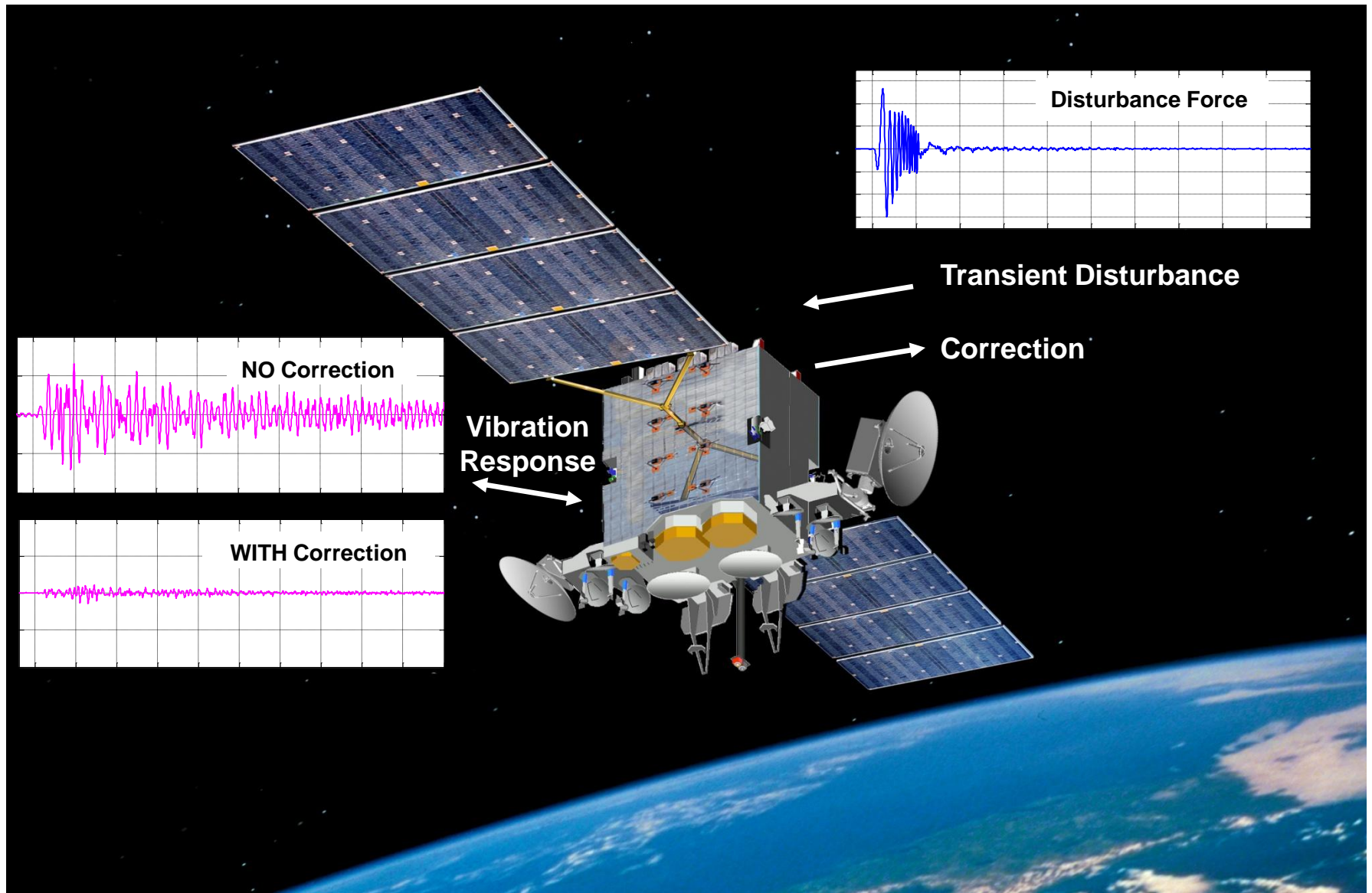

Scale model of telescope:

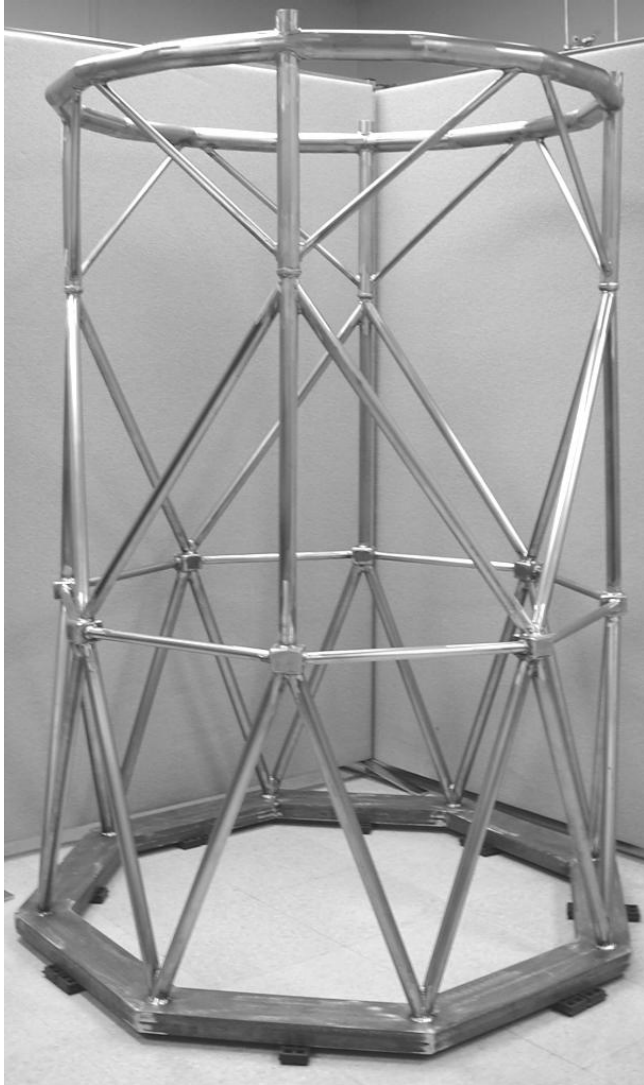

Cepstral smoothing of transfer functions:

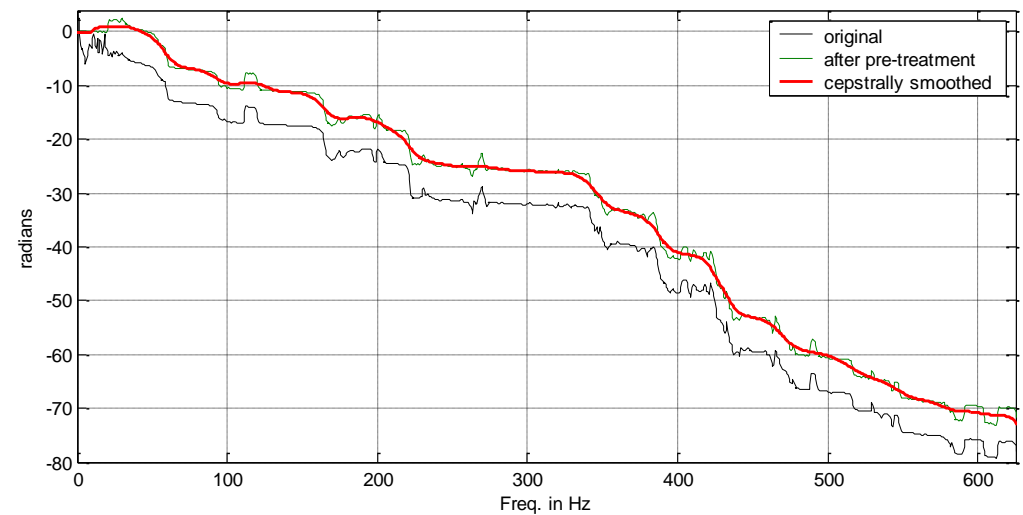
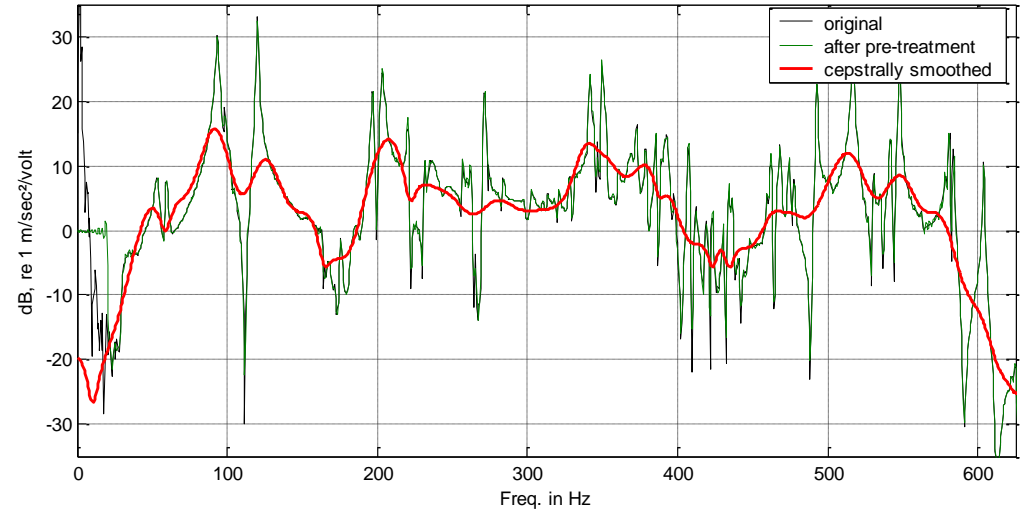

Resulting Reductions (with solenoid as disturbance device)

Adaptive Optimization Results with Solenoid as Disturbance

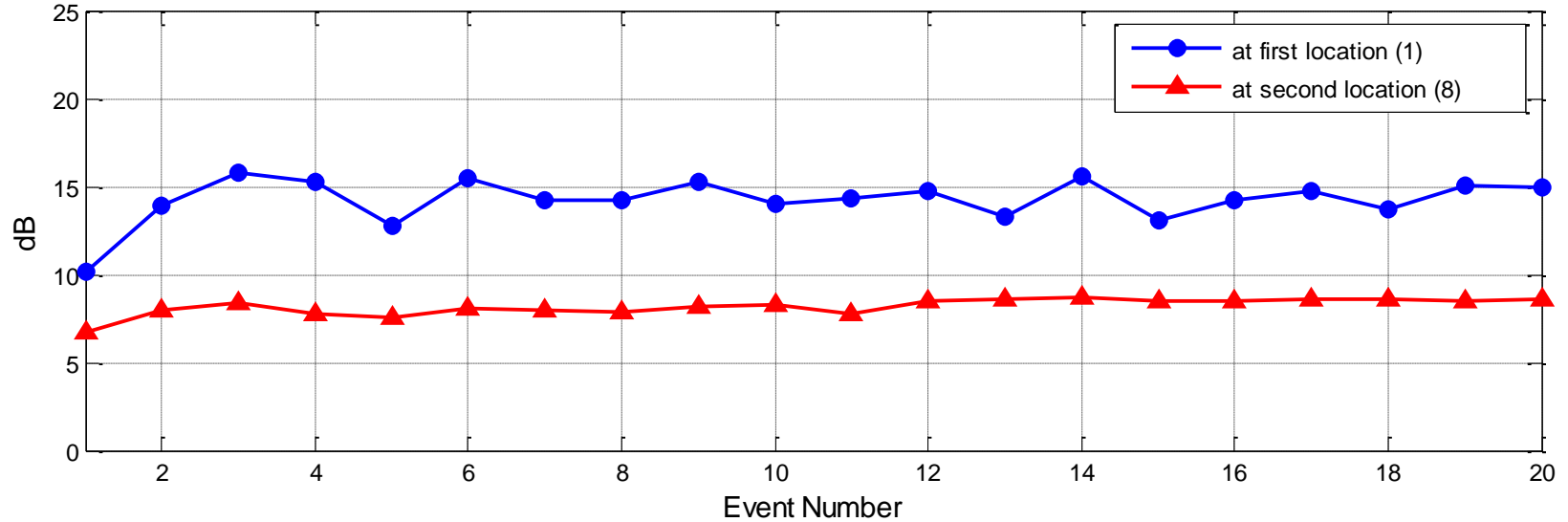

Measured disturbance and correction forces for event #6 above

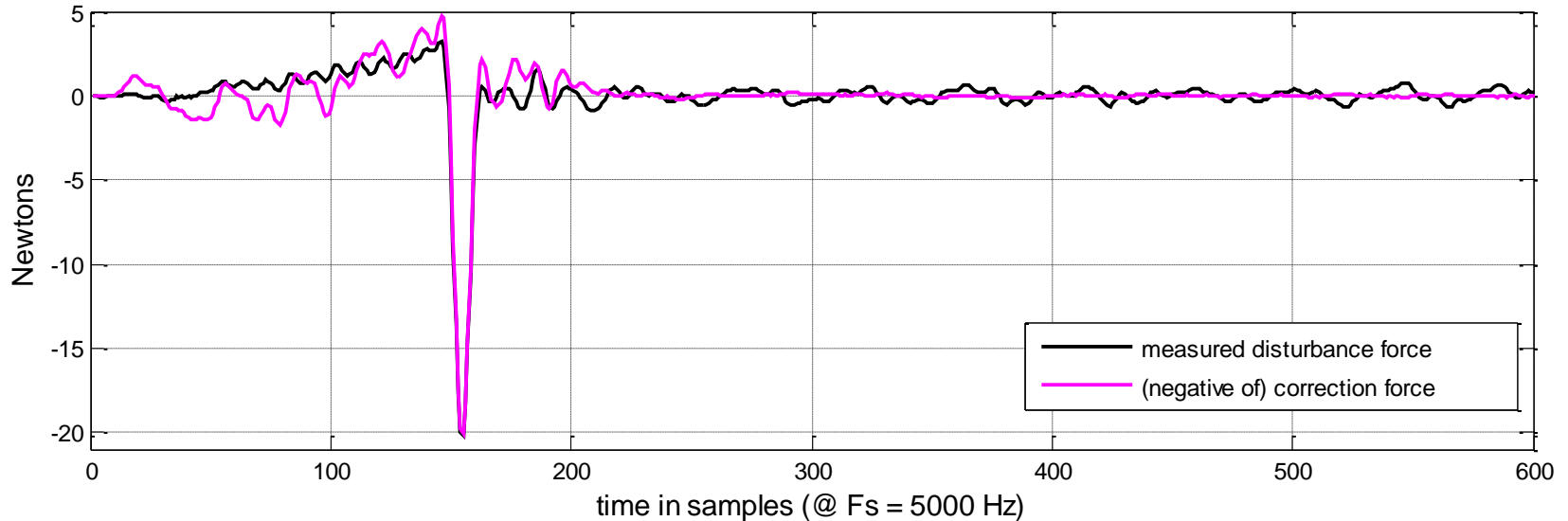

Home Theater System Design (loudspeakers & signal processing)



"THIS IS THE FIRST SPEAKER PACKAGE FROM ANY MANUFACTURER THAT OFFERS THE SOUNDFIELD CHARACTERISTICS AND FREQUENCY RESPONSE NECESSARY FOR A HIGH END THEATER SYSTEM..."

— DOLBY LABORATORIES

For years, sound reproduction technology from Dolby® Laboratories has astonished movie theater audiences by creating the sensation of being in the middle of the action through the use of sound.

impeccable sound performance for music or movies. The compact subwoofer offers superb non-directional low-frequency output which blends seamlessly with the bookshelf speakers to capture the full-range of sound from the most thrilling soundtracks.

Surround System



Center Channel



Subwoofer



Bookshelf Speaker

Tower Speaker



Other features of Video Acoustics home theater speakers are attractive oak veneer exteriors, magnetic shielding to protect against interference with your television and custom-designed drivers.

With the new Video Acoustics home theater sound system, you'll see why they say, "there isn't a bad seat in the house."

Video Acoustics Products and RH Lyon Corp have succeeded in "bringing home" all the sound sensations of a real movie theater in a space-saving home theater speaker system. In addition to the unique new center channel speaker and the single enclosure surround system, Video Acoustics utilizes either tower speakers or a bookshelf subwoofer combination to provide

DESIGN APPLICATIONS

DESIGN NEWS

From the Regional Editors

Home Theater Features Single Surround Speaker

Focus on driver radiation patterns and low-distortion design gives speakers directionality and spaciousness

Terrence Lynch, Northeast Technical Editor

Cambridge, MA—The advent of four-channel audio coding on home video media promises to produce the aural experience of a movie theater in anyone's living room. The engineering challenge lies in recreating the spaciousness and aural special effects of theaters in a smaller, less acoustically controlled environment.

To do it, Thomson RCA enlisted RH Lyon Corp, Cambridge, MA, a design firm whose experience ran more toward industrial-machinery noise analysis and "quiet design." That seemingly incongruous background let the company look at the problem without preconceptions, say company engineers. Their Video Acoustics™ home theater design uses the physics of sound and the psychology of hearing in speakers combining frequency filters, enclosure shaping, and radiation control.

The biggest hurdle in front of the home theater was creating a speaker for the "surround sound" audio channel. "In the surround speaker, you're asking for two different things: directionality for special effects and diffuse radiation for spaciousness," explains Brad Starobin, an engineer at Lyon.

To meet these conflicting demands, engineers designed a single 24-inch wide enclosure housing two opposing, side-firing woofers and two pairs of top-firing mid-range tweeters. Set up behind the viewers



Home theater audio system comprises (clockwise from top) bookshelf speakers, surround-channel module, dialog-channel module, and two-way subwoofer.

near a rear wall, the surround speaker directs most of its energy off the ceiling and side walls to create a spacious effect. This arrangement supplies the bass-response missing from dipole-radiating surround speakers and eliminates misleading directional cues given by side-mounted systems.

The long enclosure gives enough separation between the 4.5-inch woofers to limit low-frequency acoustic cancellation. The two pairs of 3.5-inch mid-range drivers were also spaced to meet the speaker's twin goals. Their radiation pattern is more or less omnidirectional at lower frequencies, becoming more lobular as frequency rises. Com-

pared with the woofers, "at lower frequencies we're sending sound out, at higher frequencies, we're sending it up," explains Lyon's Hal Greenberger. "So the sound is behind the listener but not localized."

Another thrust of the home theater design was to improve frequency response while enlarging the system's prime listening space for greater user seating flexibility. The system's center-channel or "dialog" speaker shows this work off best.

Limiting this speaker's dimensions to approximately 6.8 × 13.6 × 11 inches facilitated its placement atop the TV to correlate dialog with the actors on the screen.

“Delevator”

CONSTANTLY IMPROVING THE HOME THEATRE EXPERIENCE.

PROBLEM:

Since center channel speakers have to be displaced vertically from the center of the television screen, viewers may be conscious of a lack of “fusion” between on-screen images and their corresponding sounds.

This problem is especially acute for large screen TVs and in-wall speakers where, typically, speaker-to-screen displacements are large.

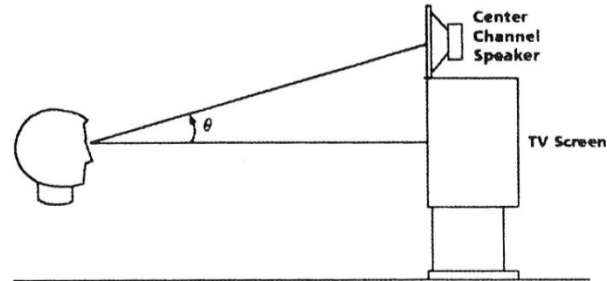

Schematic depicting geometry of viewing situation. The delevator shifts the sound image so that it is perceived to originate from the television screen.

THE VIDEO ACOUSTICS SOLUTION:

DELEVATOR™

- Sounds originating from in front of us are heard differently as the height of the sound source changes. The delevator adjusts the frequency response of the center channel so that it closely resembles the frequency response of a sound source located directly in front of the viewer. Thus, soundtrack dialog becomes riveted to the television screen.
- The delevator will incorporate multiple settings to adjust to most typical television/center channel speaker configurations.



BRINGING TRUE THEATRE SOUND TO THE HOME

Illustration of How the Ear Hears Sounds at Different Elevations

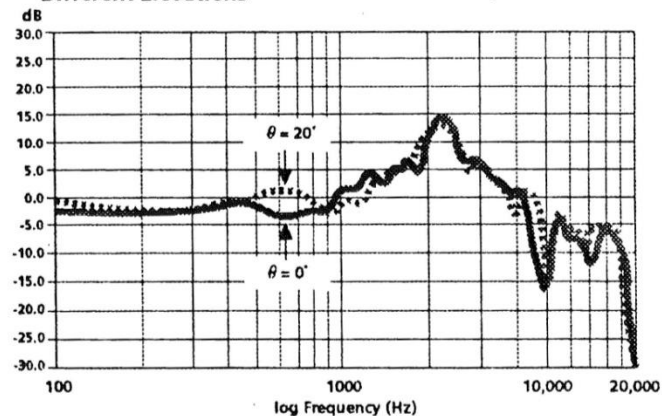

Frequency response measured at the eardrum for a sound source at two different elevation angles.

(More) Transducer Design

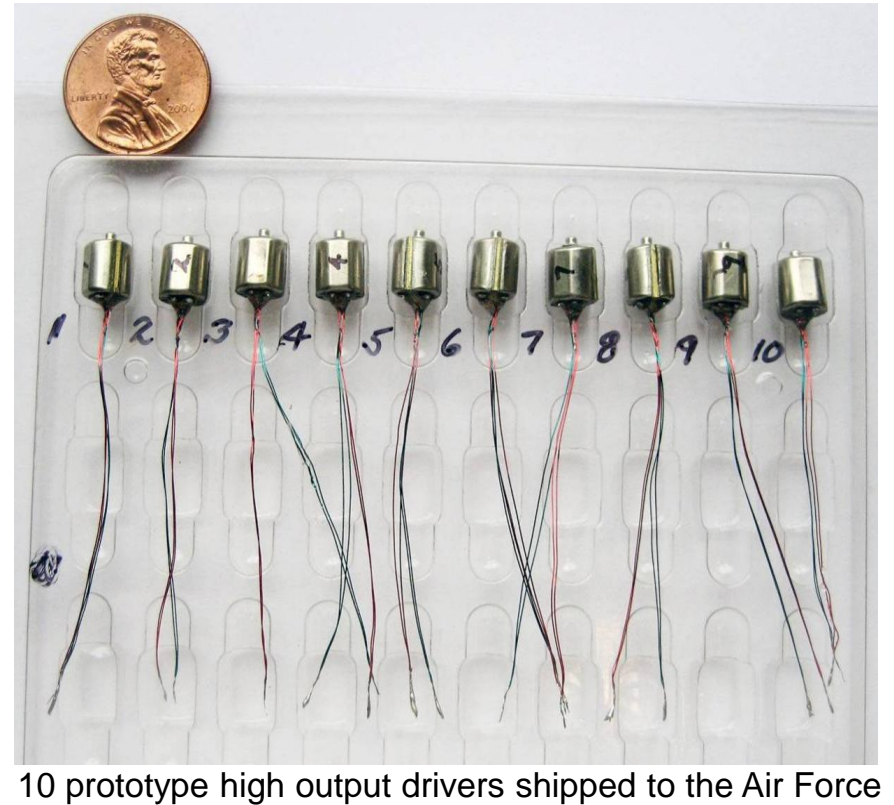
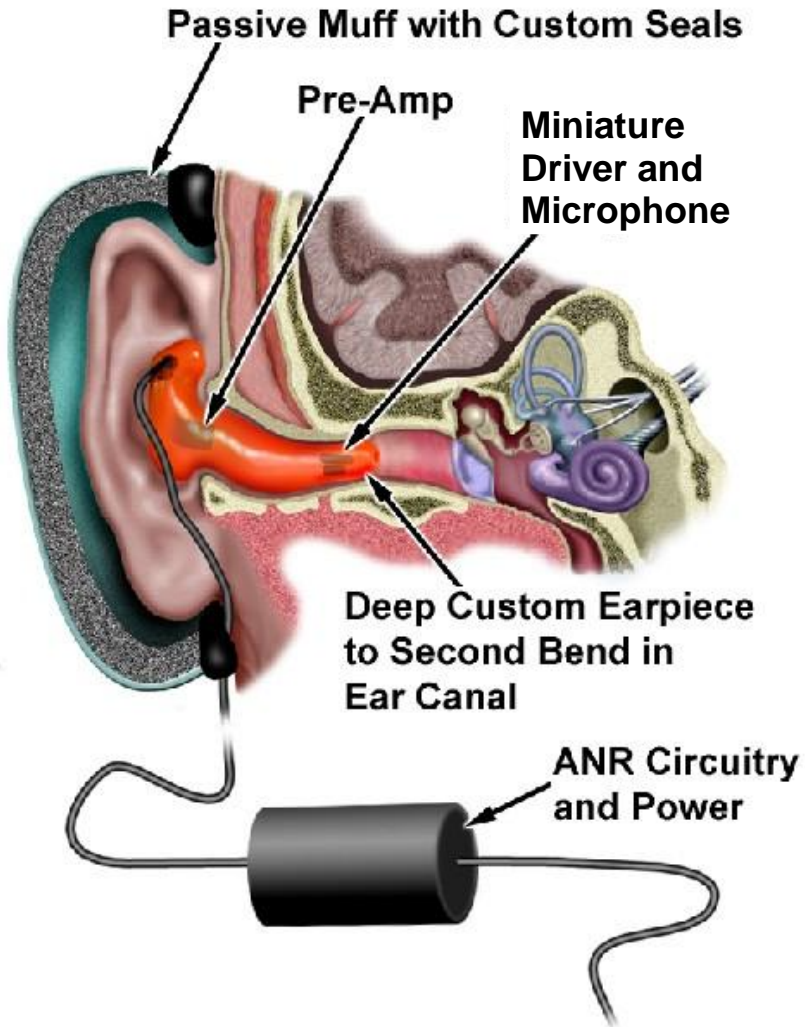

Dual Element Balanced Armature Design

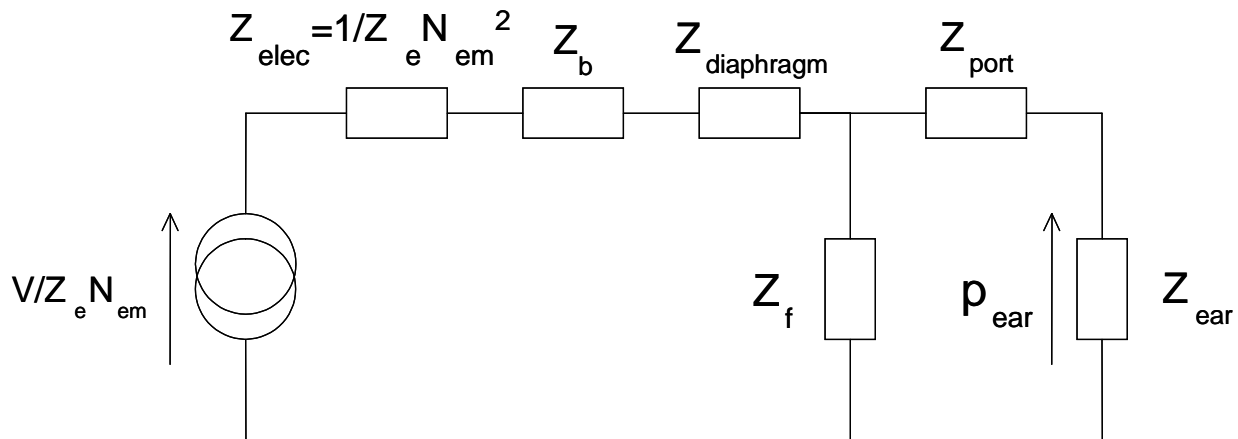
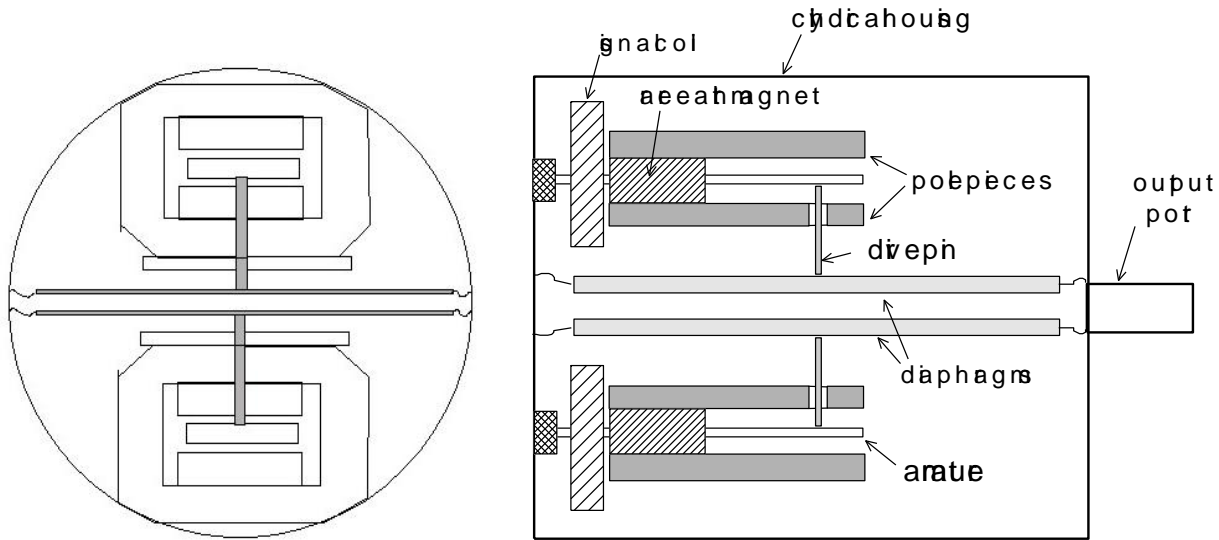

Circuit diagram model for the balanced armature driver

Push-Pull Bimorph and Electret Designs

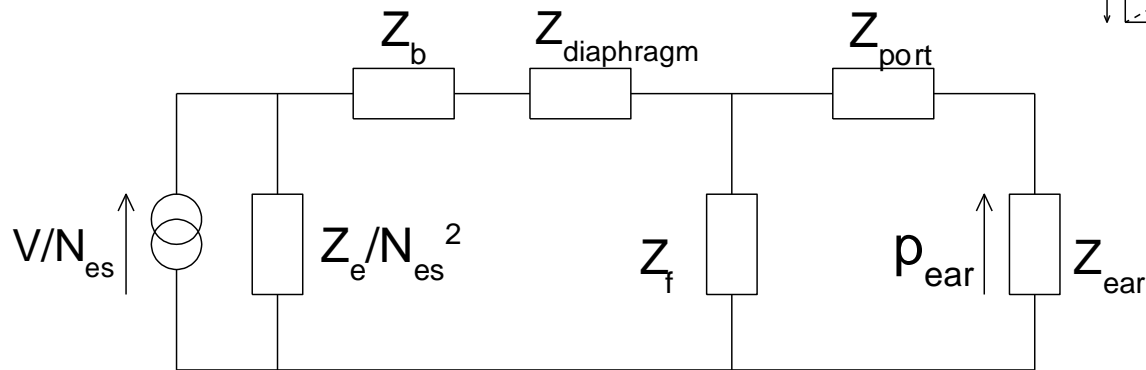
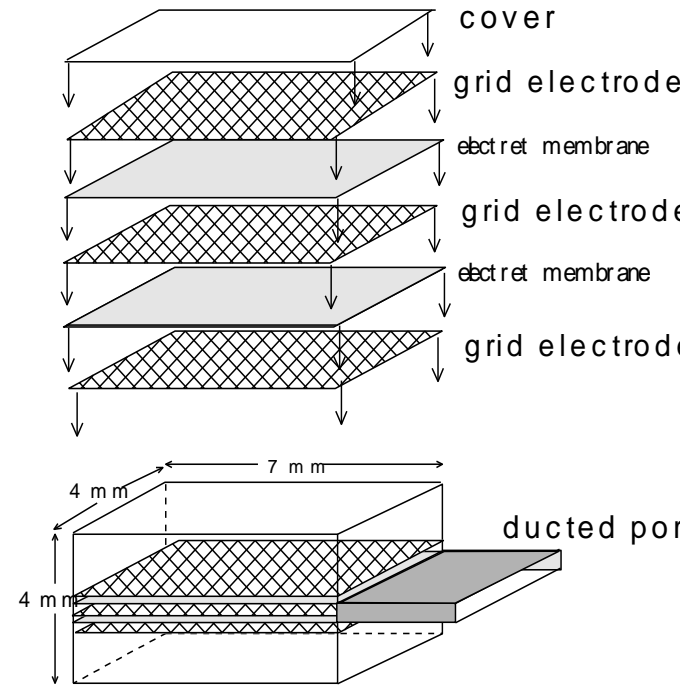
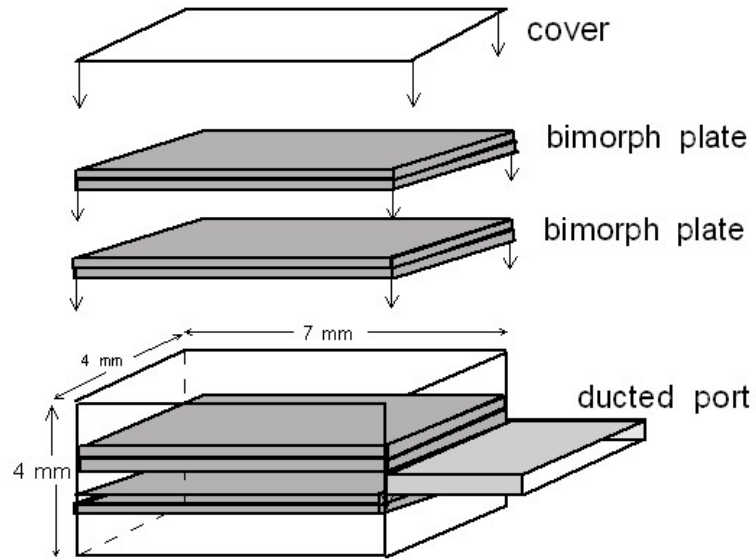

Circuit diagram models for above designs

Sound Quality

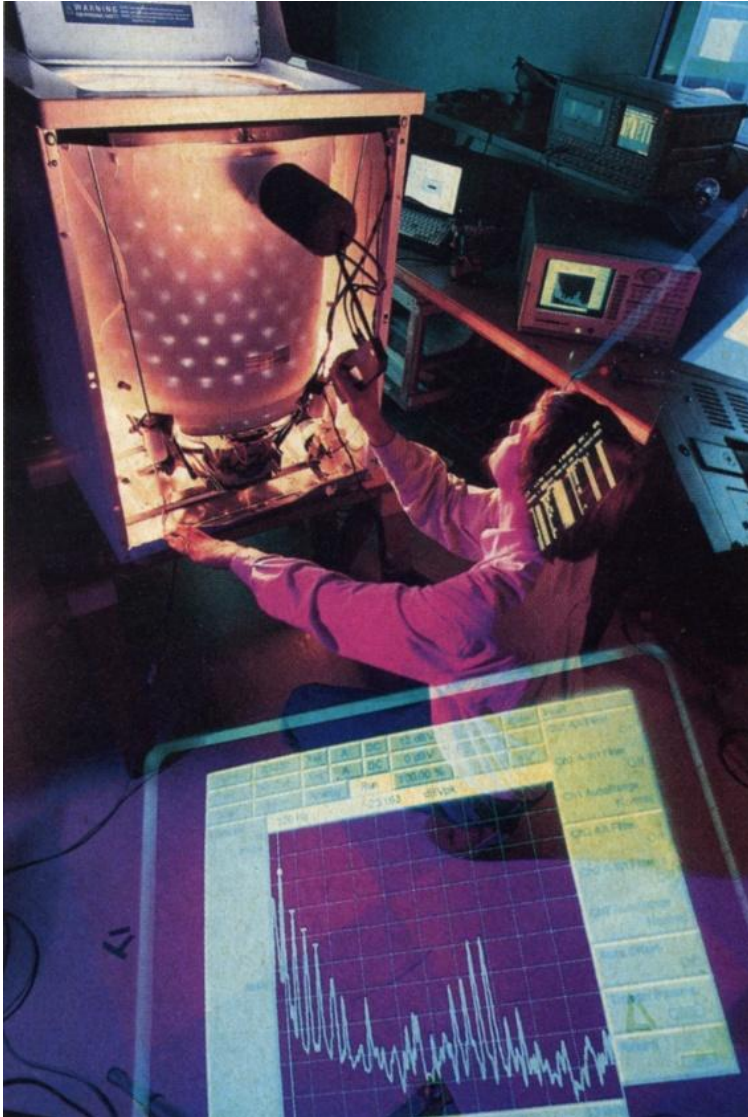

Sound Quality (con't.)

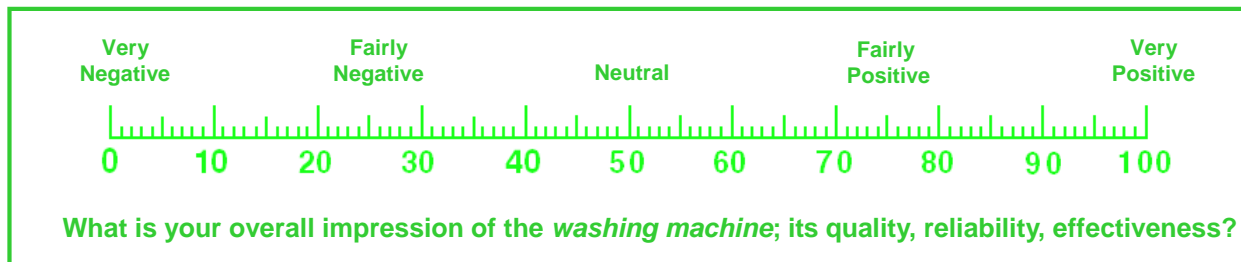

Resulting Response Surface Contours Show Route to Better SQ Designs

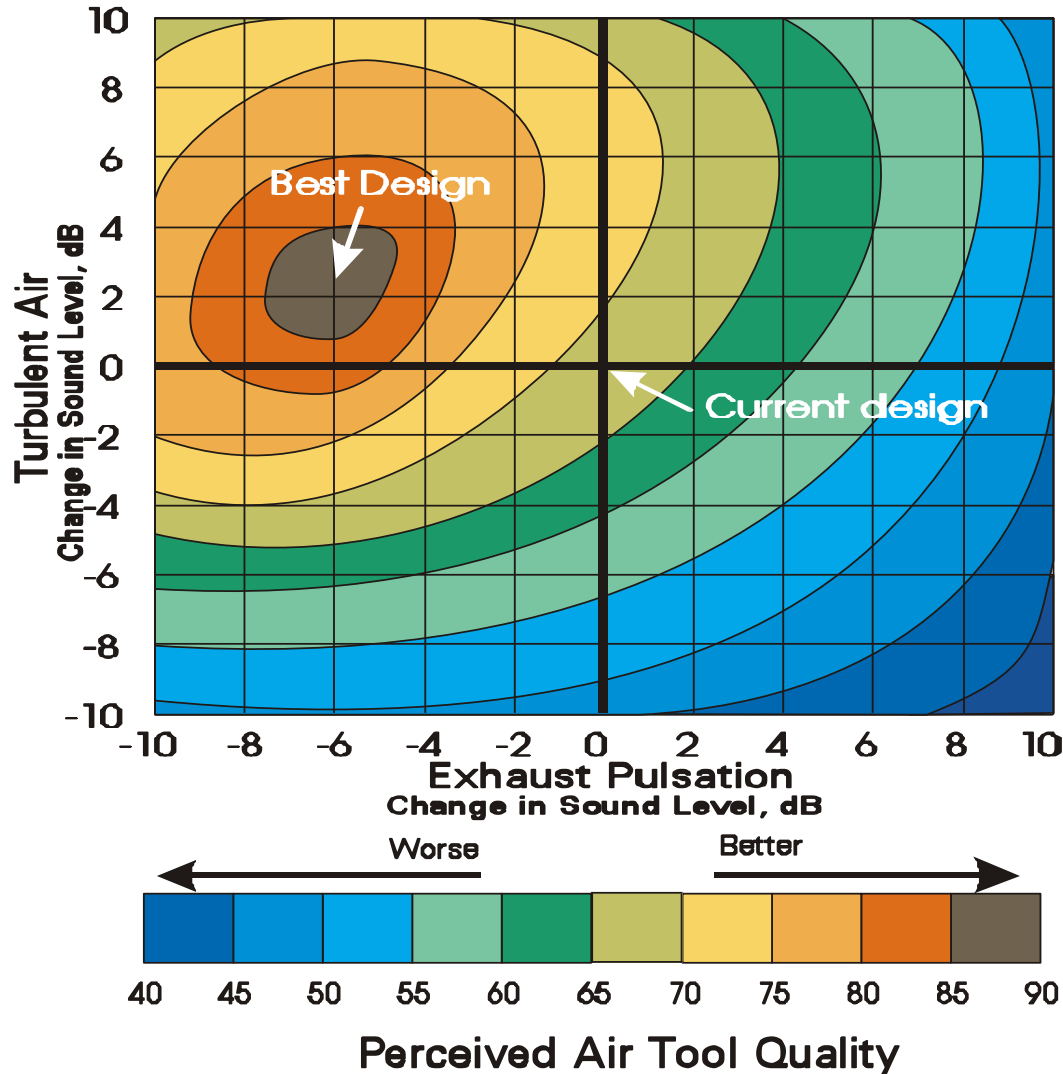

(Air tool example)

- Quantifies tradeoff between perceived SQ and changes in sound levels of the various components.
- Contours show designs of equal SQ values.

Slides presented for Dick Lyon by Gladys Unger, Senior
Consultant at Acentech

RH Lyon Corp – All in the Family

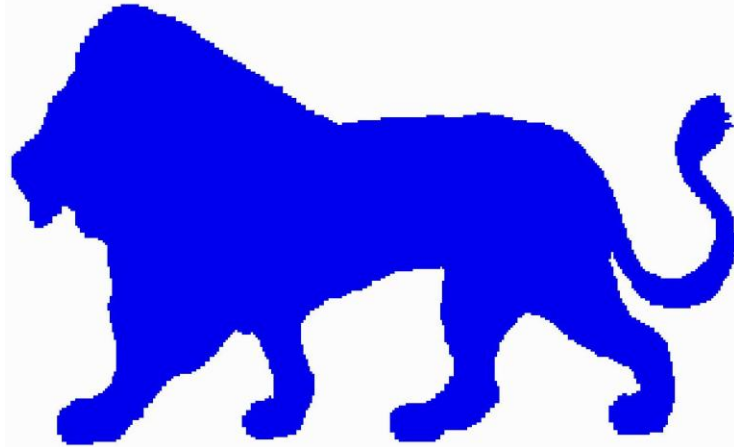

Gladys Unger, Ph.D.

Senior Consultant, Noise & Vibration Group

ACENTECH

33 Moulton Street

Cambridge, Mass.

Acoustics AV/IT/Security Vibration

Product Noise and Vibration Reduction

We view sound and vibration as the manufacturer's allies. Properly modified, sound can enhance a product's image and appeal. Properly understood, vibration signatures can provide sensitive diagnostics.

Sound Provides Context

ROBOTMAN by Jim Meddick



Product Noise Projects

Vacuum Cleaners	Blenders
Dishwashers	Shop Vacs
Washing Machines	Pumps
Fans	Compressors
Dehumidifiers	Air-powered Tools
Air Conditioners	Lawn Mowers
Hair Dryers	String Trimmers
Refrigerators	Leaf Blowers
Sewing Machines	Garage Door Openers

Product Noise Projects

Copiers	Plug-in Air Fresheners
Computer Hard Drives	Toys
Digital Projectors	Cell Phones
Sleep Apnea devices	Electrically Powered Window Shade
Oxygen Concentrators	Liquid Soap Dispenser
Centrifuges	Cameras
Golf Clubs	Night Vision Goggles
Powered Toothbrushes	Diver's Helmet Air Regulator
Mechanical Baby Swing	Elevators



In the beginning...

HARD H. LYON/60 PRENTISS LANE/BELMONT, MASS. 02178/(617) 489-2112

EFFECTS OF DESIGN CHANGES ON THE OPERATING SOUND
VACUUM CLEANERS

Richard H. Lyon
W. Eugene Bachman
Rebecca N. Fleischman

9 July 1980

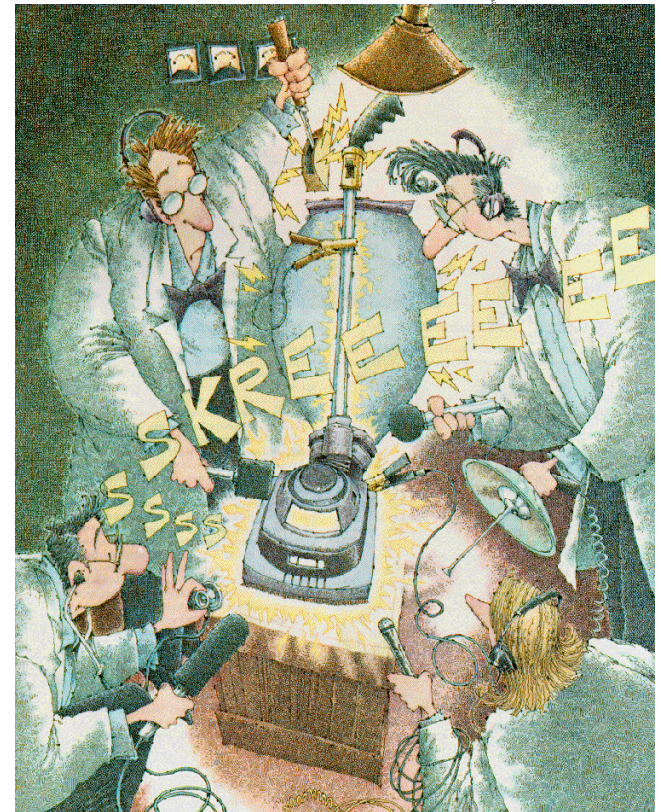

Dick Lyon: lover of all things that go vroom...



Noise Audit of a Riding Lawn Mower



Venting the Exhaust Gases



Covering Noise Sources



Covering Noise Sources



Sound Trademarks



Origin of the Harley Sound

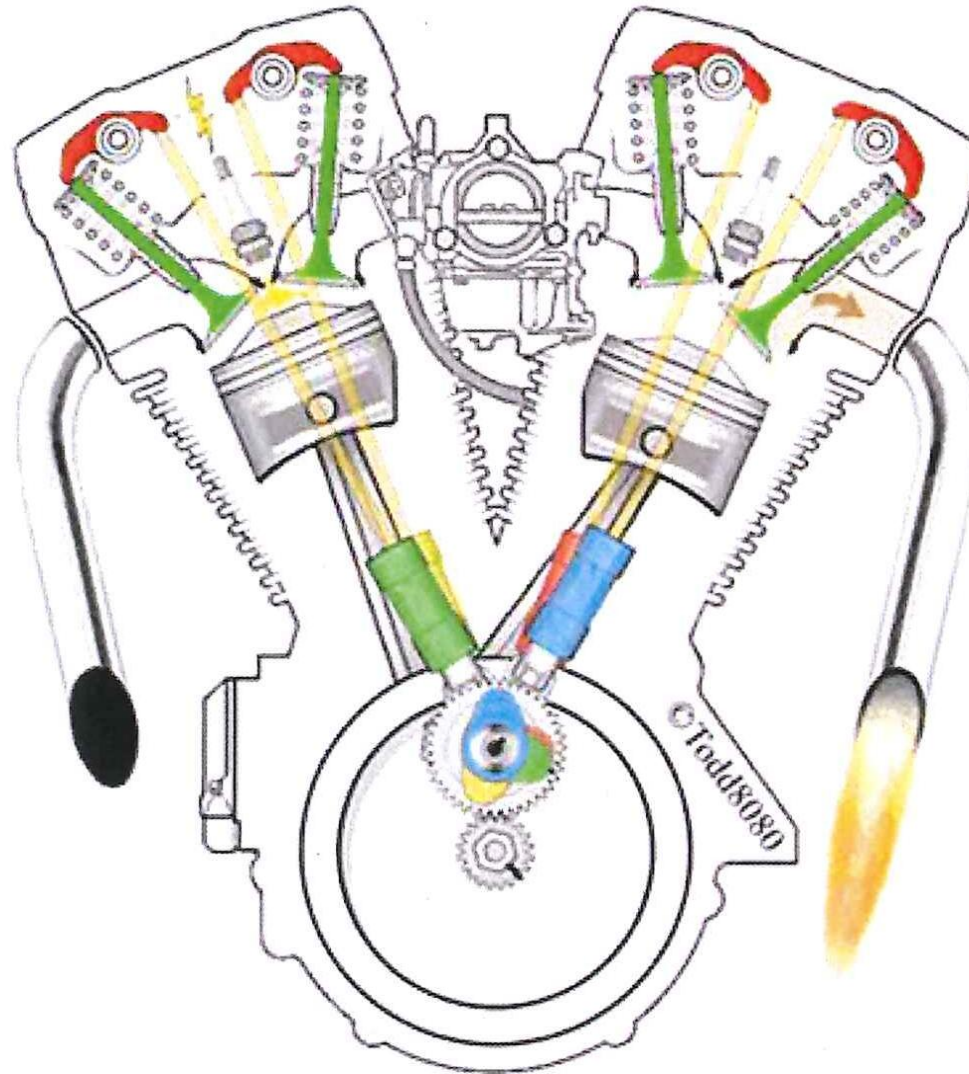

Origin of the Harley Sound

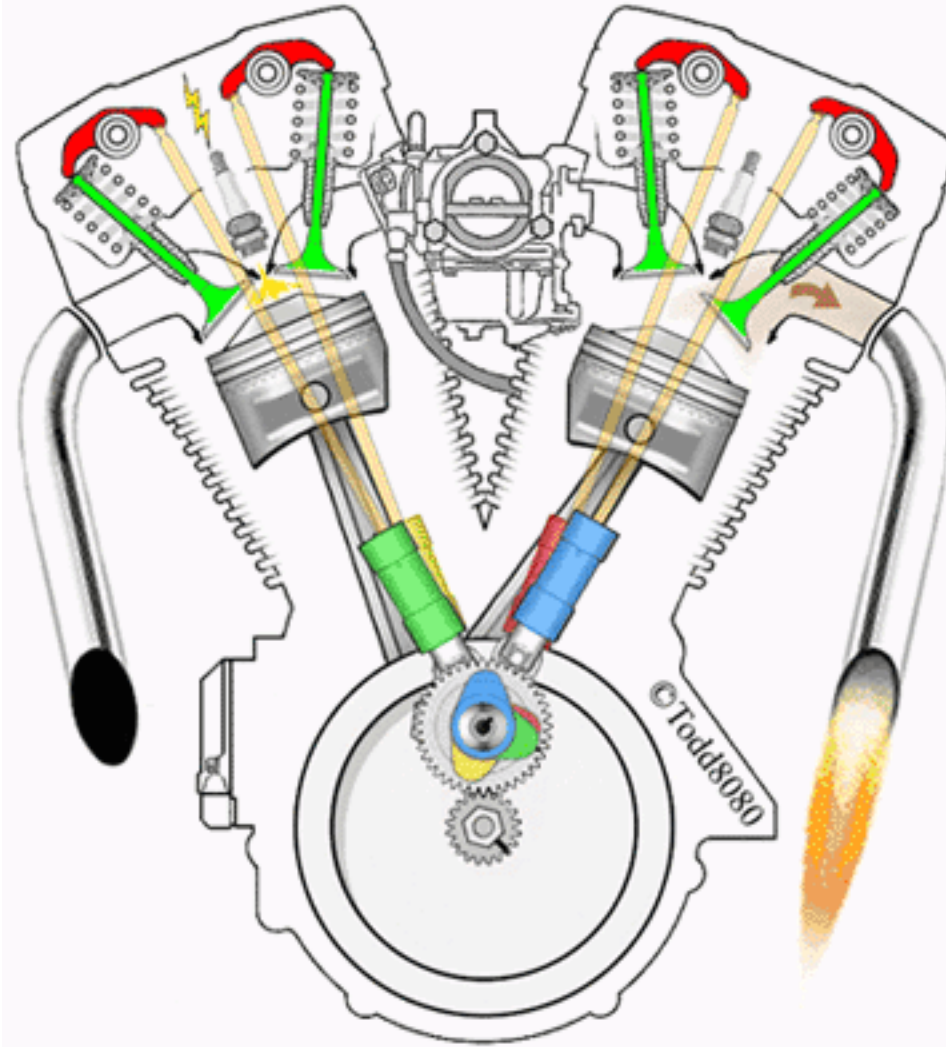

Sound Trademark for Harley Davidson



Investigating a “Defect”

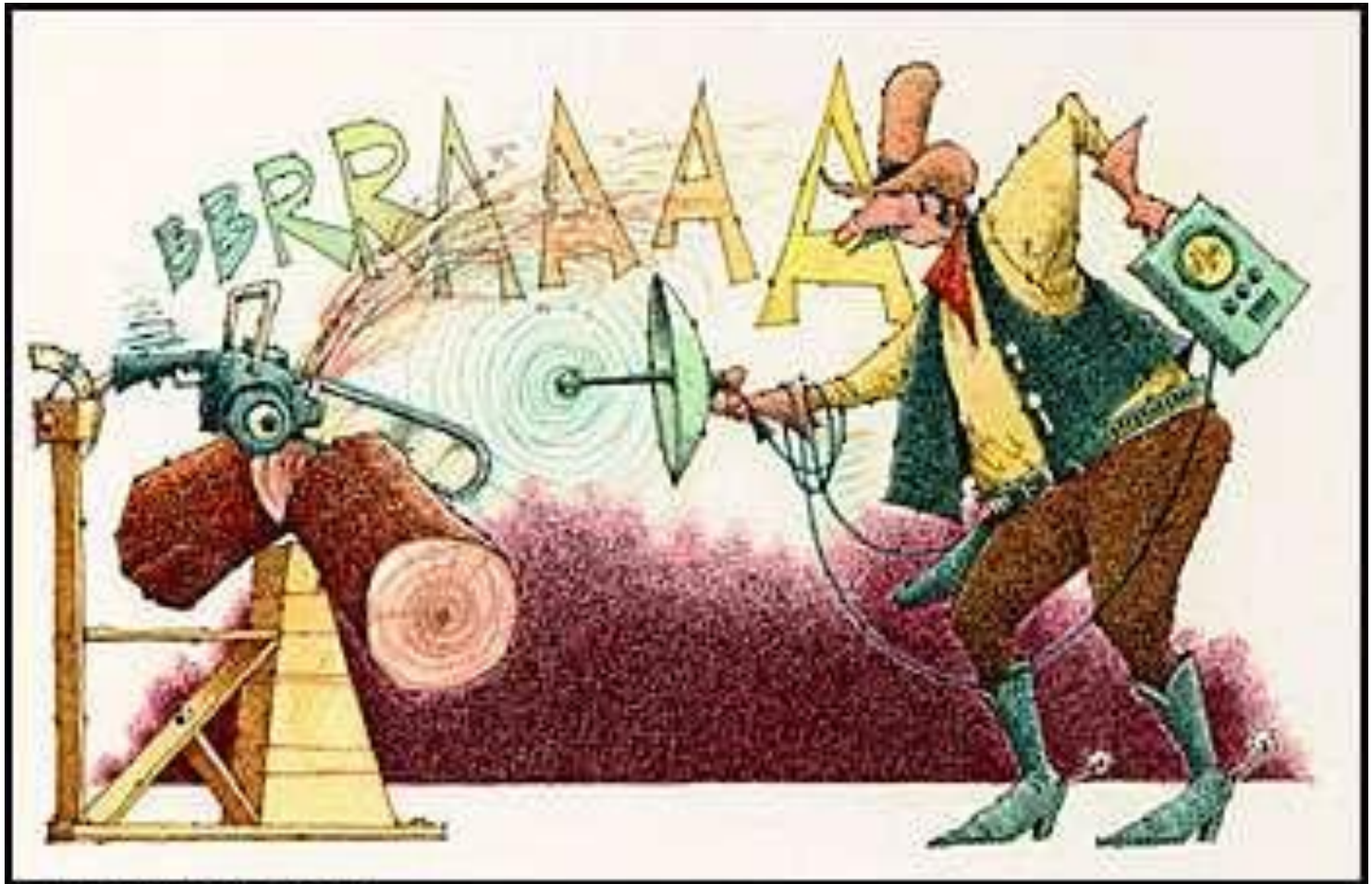

© Jeff Seaver, 1995

Jeep Engine Knock

- Plaintiffs allege: that their 4.0L Jeep Cherokees, Model years, 1991-1996, are defective due to an idle knocking noise in the engine.
- Plaintiffs request judgment: repair engines or refund the cost of their warranties
- Chrysler formed an “idle knock task force” to investigate

Jeep Engine Knock

- Plaintiffs hire Richard Lyon to be their expert witness in the case of Hasek v. DaimlerChrysler

Defect in Product Sound

A product is defective when it fails to provide the performance, utility, and/or enjoyment that the provider promises (expressly or by implication) or the user has a right to expect. **When a product produces a sound that is unexpected and of such a nature as to annoy the user or promote anxiety and loss of enjoyment on the part of the user, the product is defective because of its sound.** If that unusual and unexpected sound is not present, there is no defect due to sound, even though there may still be a defect in the construction or operation of the product. A defect in the sound is as much of a product defect as a mechanical condition that would lead to failure or diminished performance of the product.

Tasks in Preparation for Testimony

- Reviewed over 60,000 Chrysler documents.
- Measured engine timing, 5 accelerometer signals, and 1 microphone signal.
- Analyzed above recordings as well as those made by Chrysler.
- Was deposed.



End Result(s)

- The suit was settled in Chrysler's favor “the mere fact that the car made noises is not proof that these difficulties were caused by defects....”
- Sue left for graduate school – and not in acoustics!

Slides presented for Dick Lyon by Rich De Jong co-author with Dick on the second edition of their highly regarded textbook, *Theory and Application of Statistical Energy Analysis*.

Dick Lyon

SEA and More

Richard G. DeJong
Sc.D. MIT 1977

New England
NoiseCon-16:

June 13-15, 2016
Providence, Rhode Island

Revolution in
Noise Control

A map of New England showing parts of Massachusetts, Rhode Island, and Connecticut. A black pushpin is stuck into the map, pointing to Providence, Rhode Island. The map includes labels for various cities and regions such as Boston, Worcester, Springfield, Hartford, and Cape Cod.

SEA

SVM-1

Random Noise and Vibration in Space Vehicles

Richard H. Lyon
Bolt Beranek and Newman Inc.

1967



The Shock and Vibration Information Center
United States Department of Defense

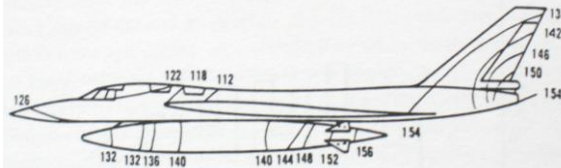

Fig. 11. Contours of constant L_p on B-58 airplane for 600 to 1200 Hz octave band [40].

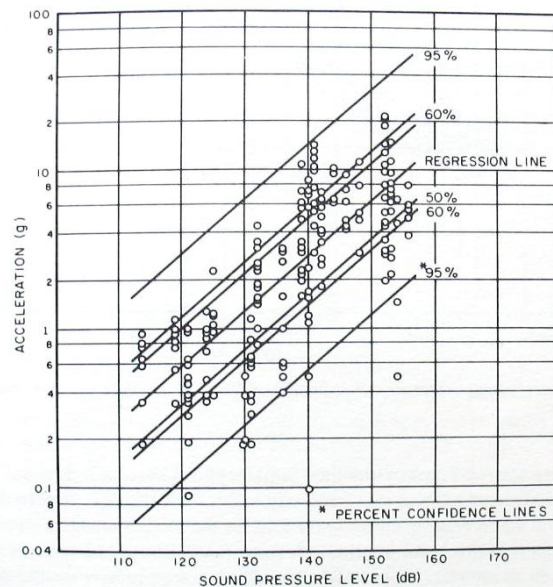

Fig. 12. Scatter diagram of acceleration levels L_a on B-58 airplane plotted against pressure levels L_p in 600 to 1200 Hz octave band [40].

STATISTICAL ENERGY ANALYSIS OF DYNAMICAL SYSTEMS

THEORY AND APPLICATIONS

RICHARD H LYON

MIT PRESS

Acoustical Scale Modeling

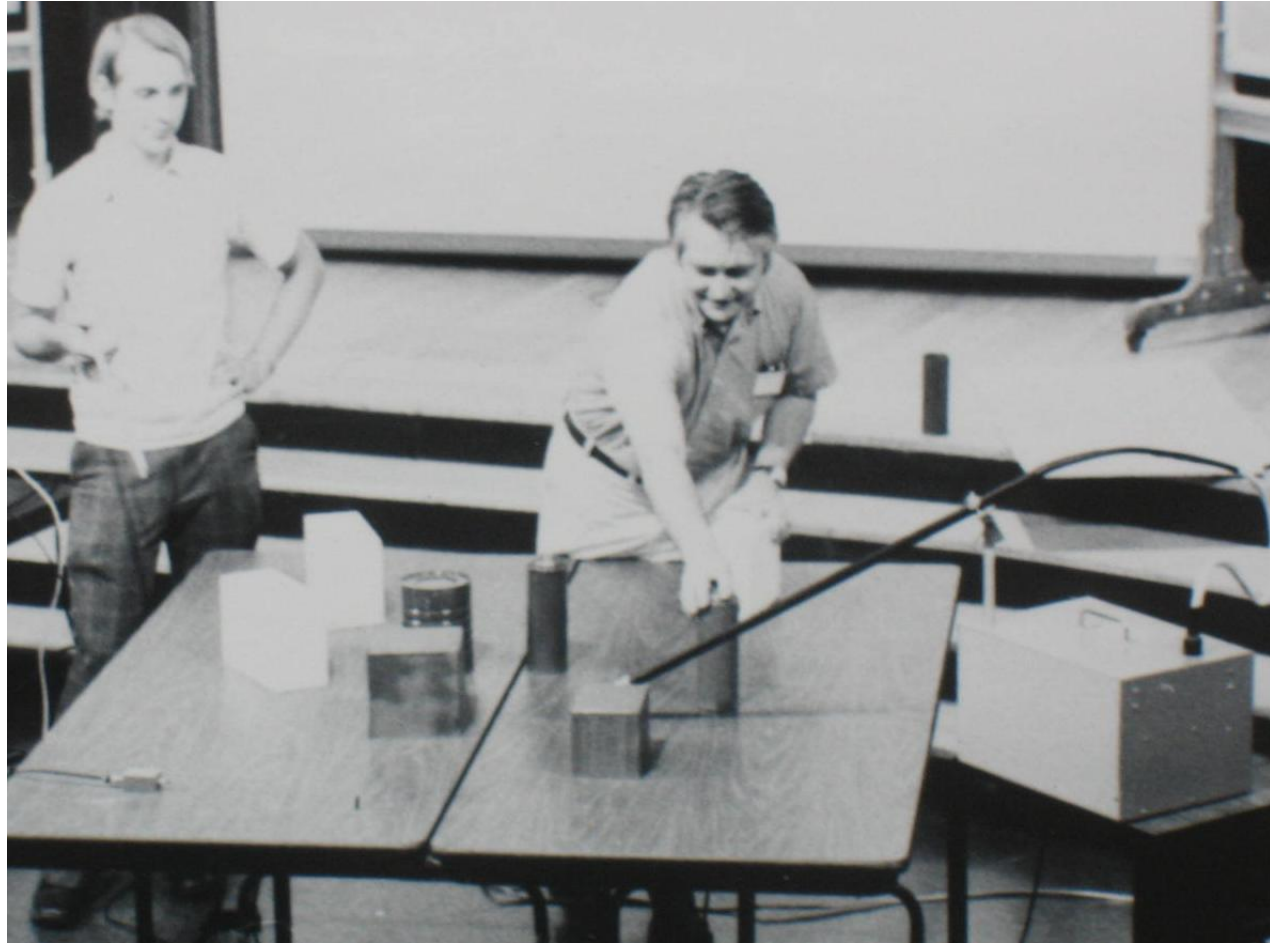
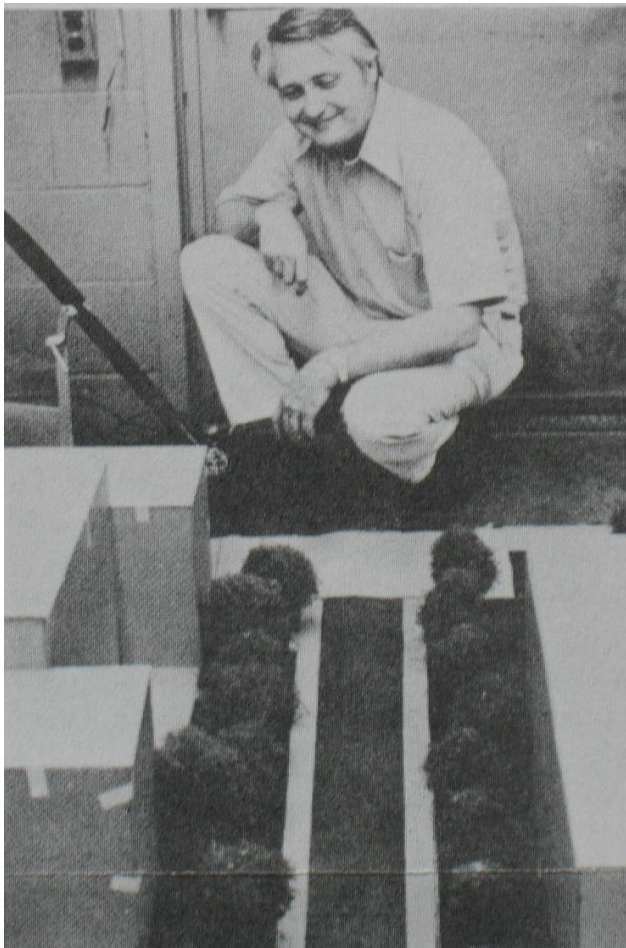

Machinery Noise

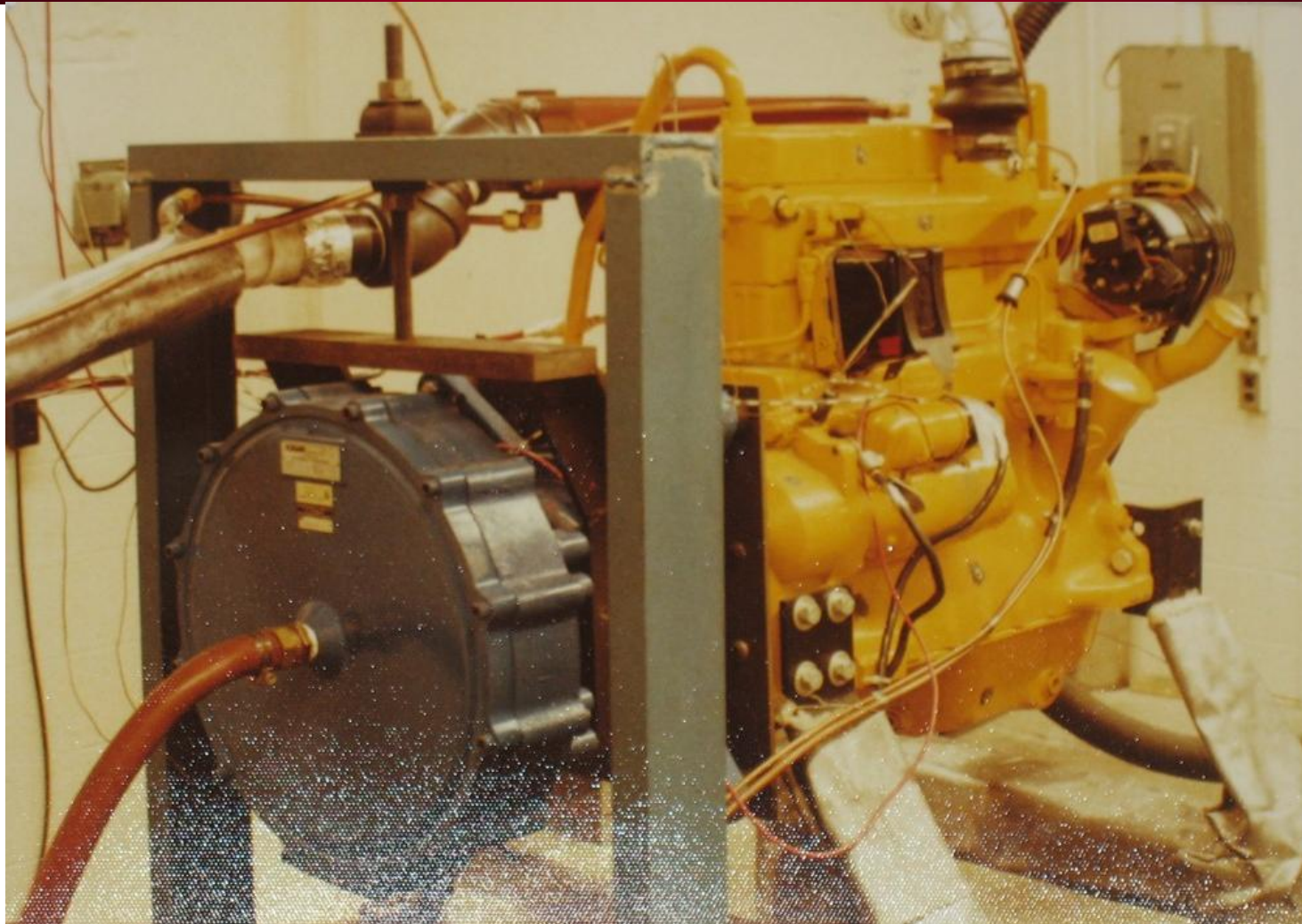

Machinery Diagnostics

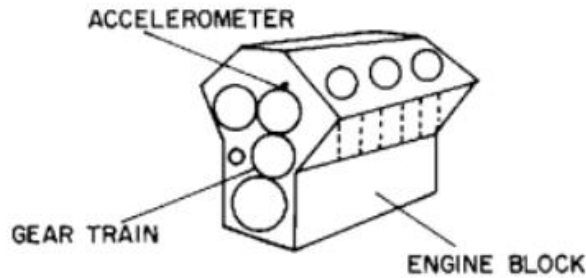

a) LOCATION OF ACCELERATION MEASUREMENT

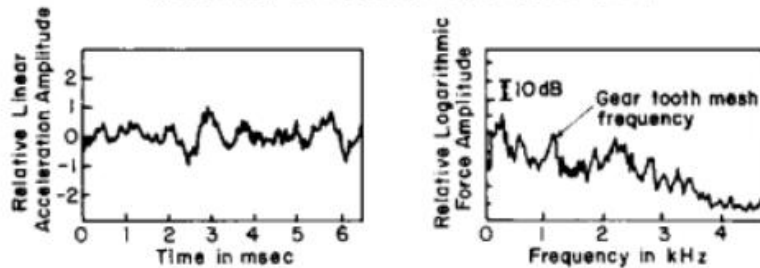

b) MEASURED ACCELERATION SIGNALS ON GEAR BEARING

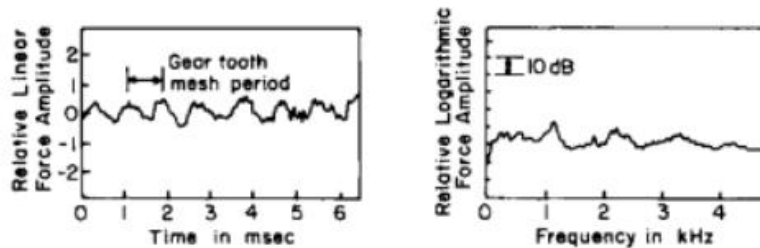

c) CALCULATED FORCE SIGNALS OF GEAR MESH EXCITATION

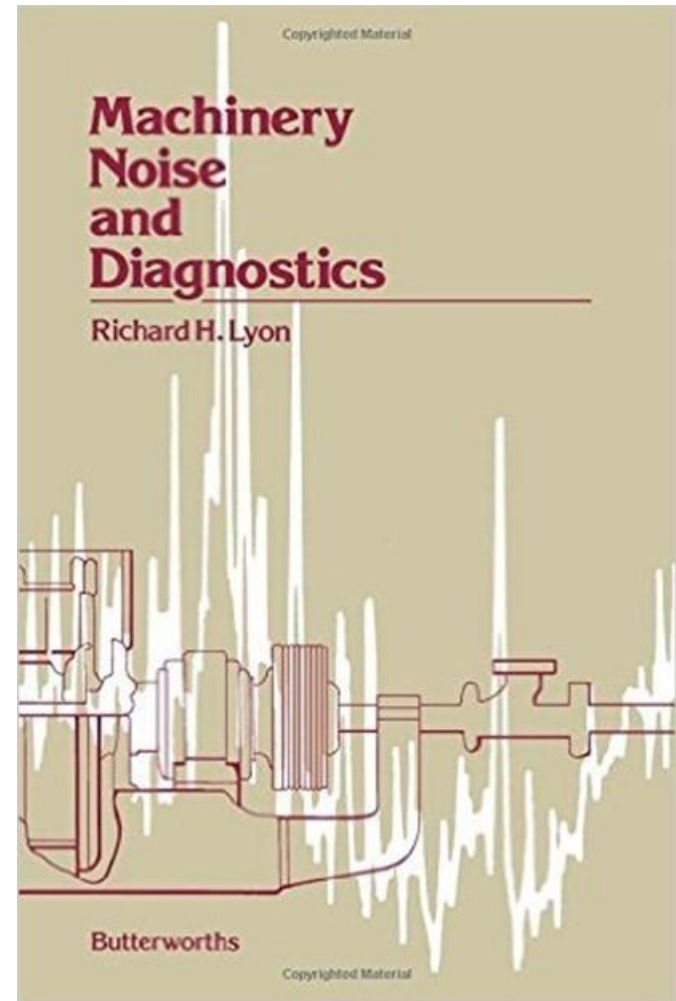

Sound Quality



Marine SEA

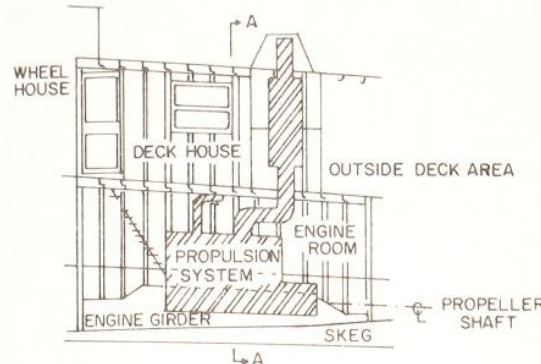
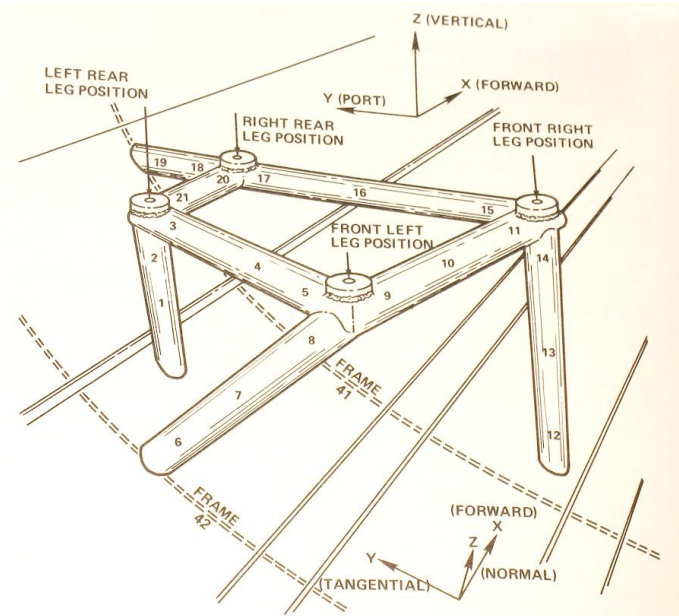

Schematic Centerline Section of Vessel Engine Room and Deck House

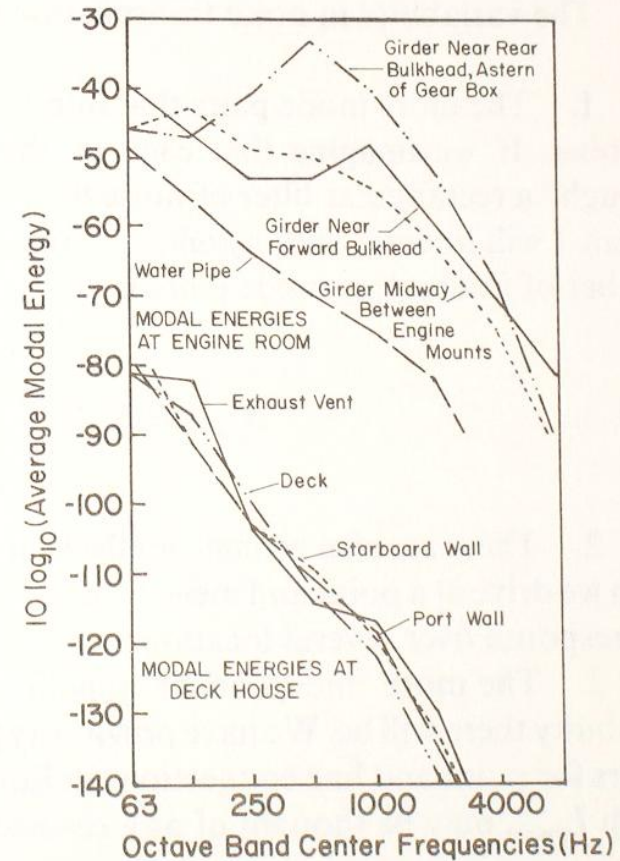
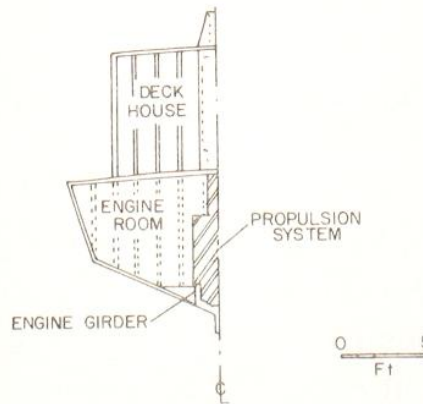

Marine SEA

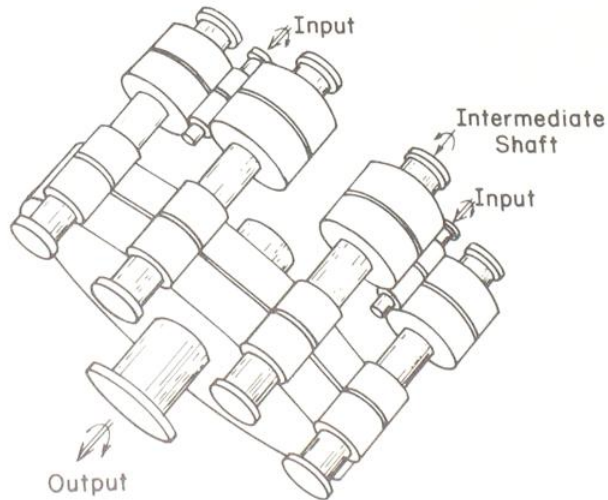
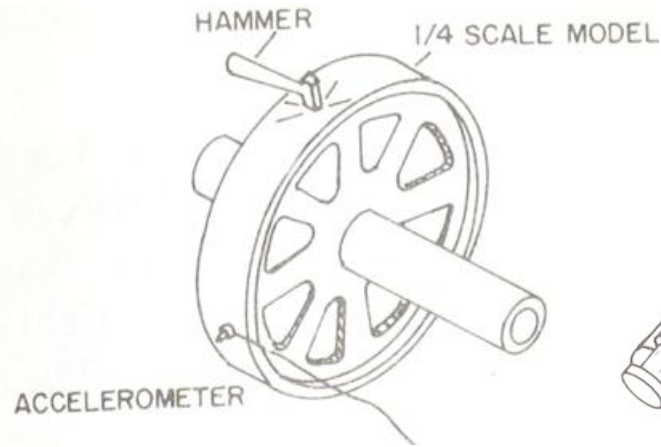

Copyrighted Material
THEORY
AND
APPLICATION
of

STATISTICAL ENERGY ANALYSIS

SECOND EDITION



RICHARD H. LYON / RICHARD G. DeJONG
Copyrighted Material

New England
NoiseCon-16

Statistical Phase Analysis

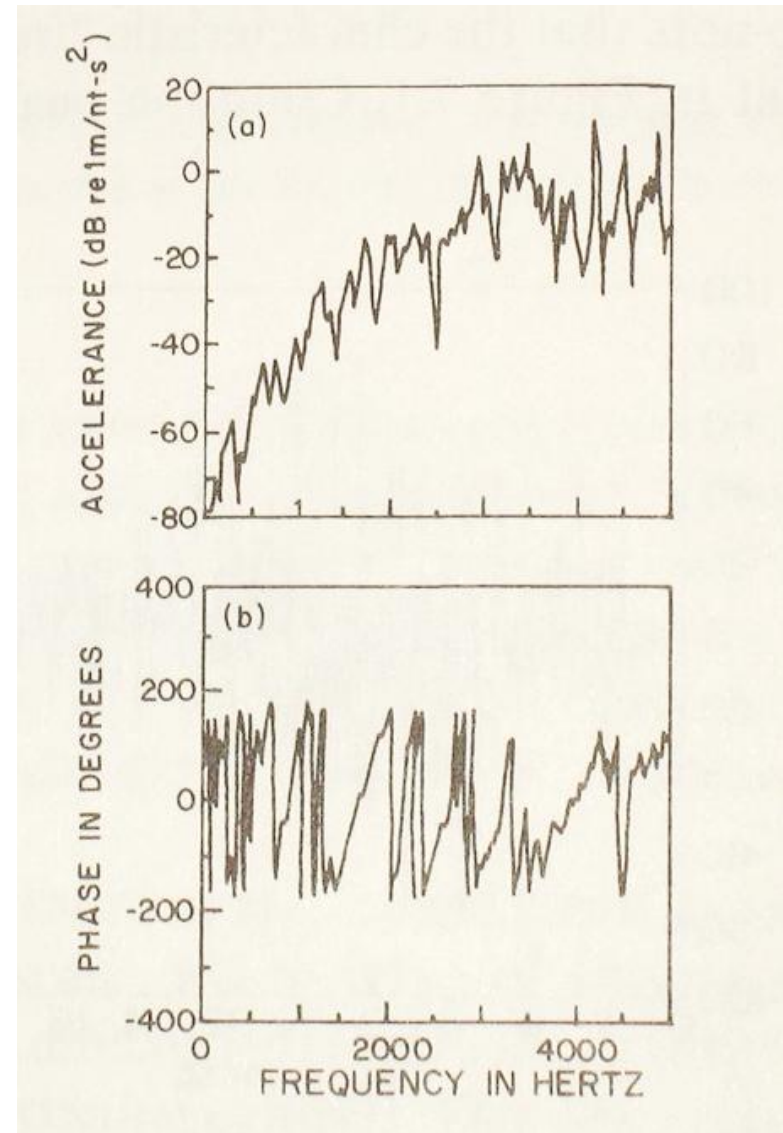
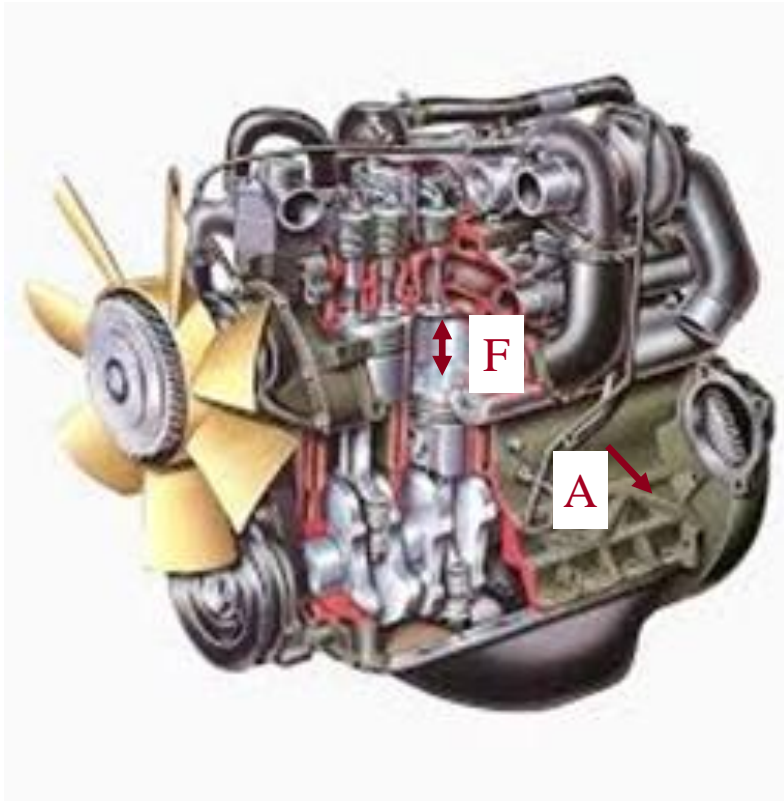

Statistical Phase Analysis

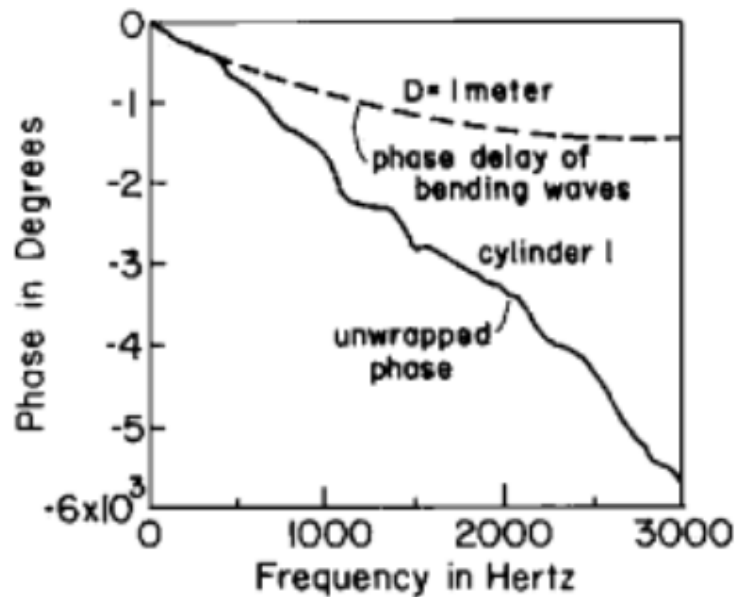
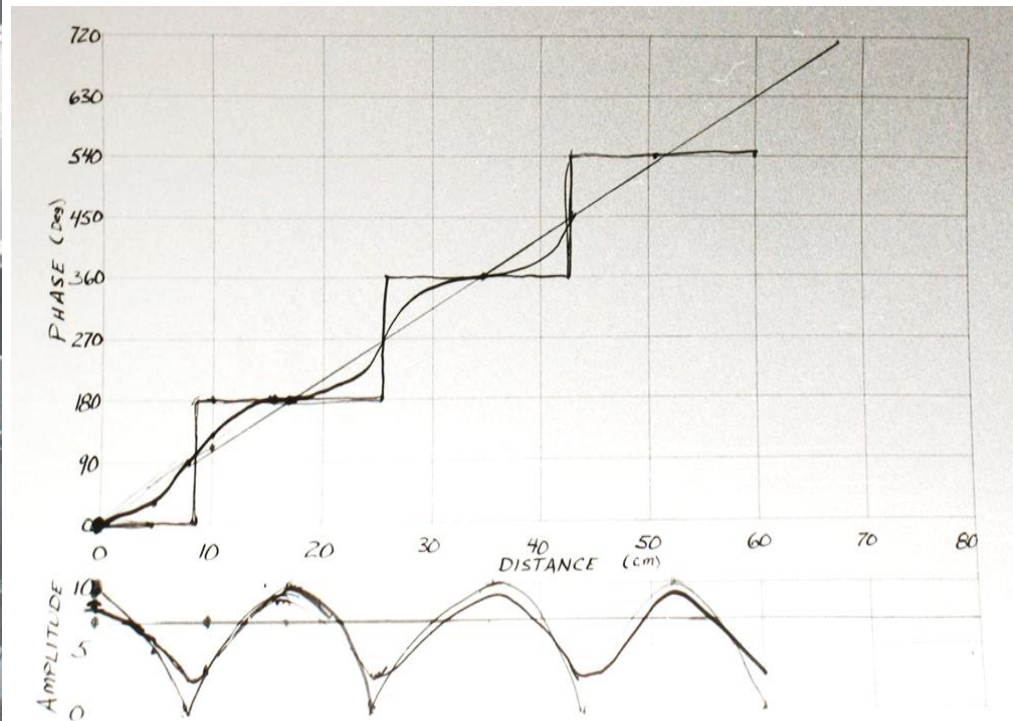
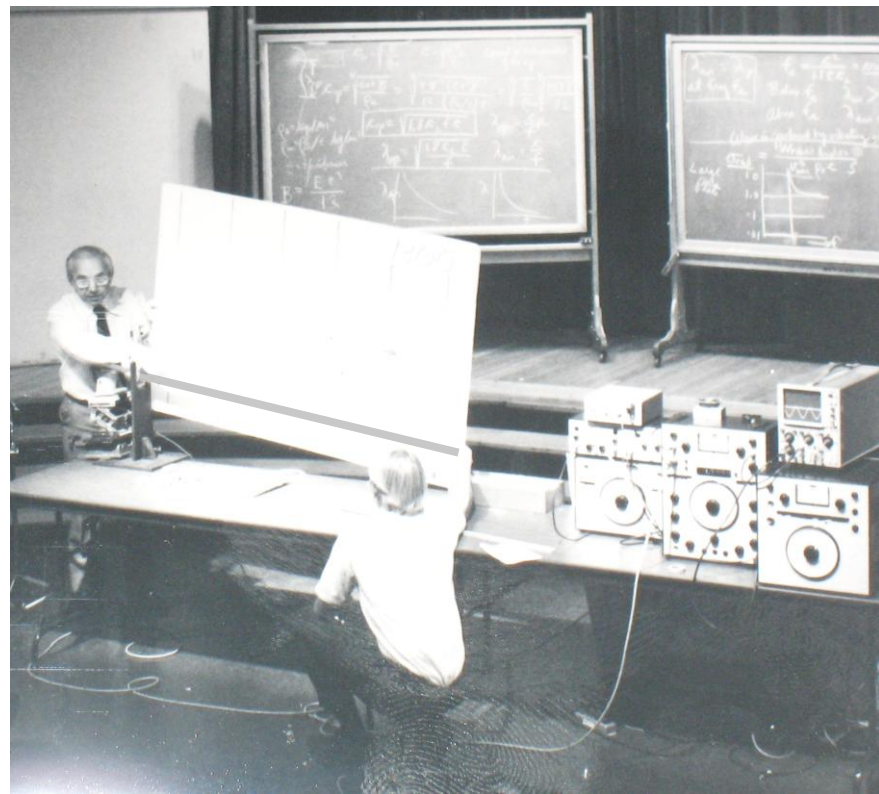

Figure 7.6 Unwrapped phase of diesel engine transfer function. The progressive phase exceeds the flexural wave propagation phase by a significant amount.

Statistical Phase Analysis



$$\psi(x) = A \cos(kx) + B \sin(kx) + C \cosh(kx) + D \sinh(kx)$$

Statistical Phase Analysis

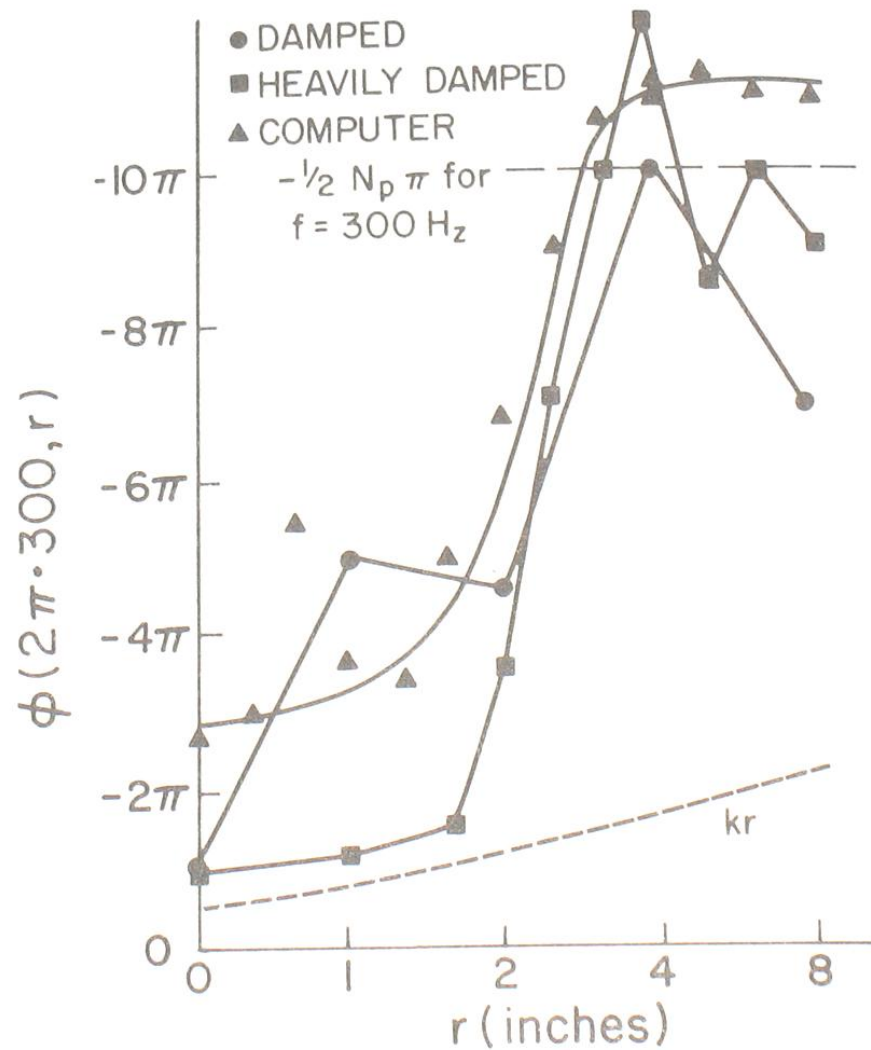
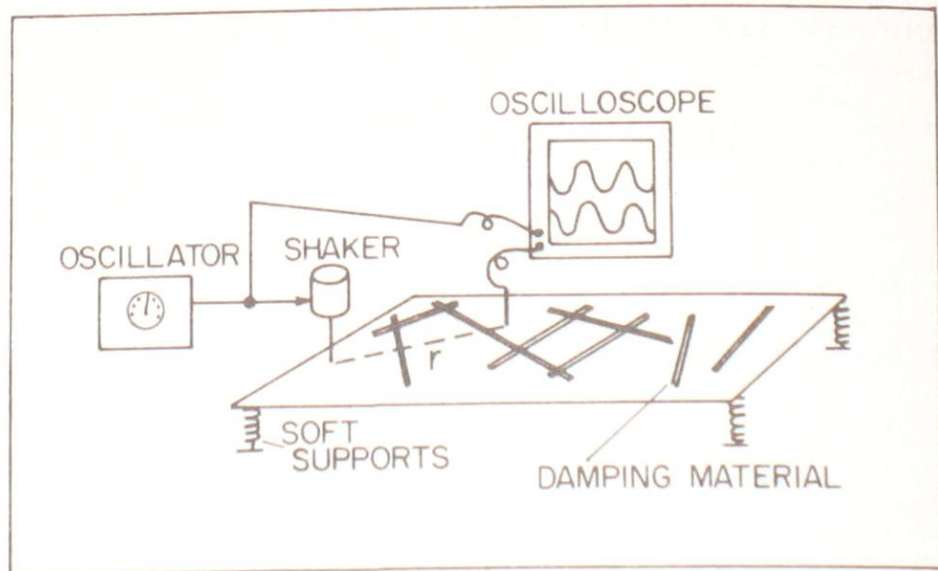

Statistical Phase Analysis

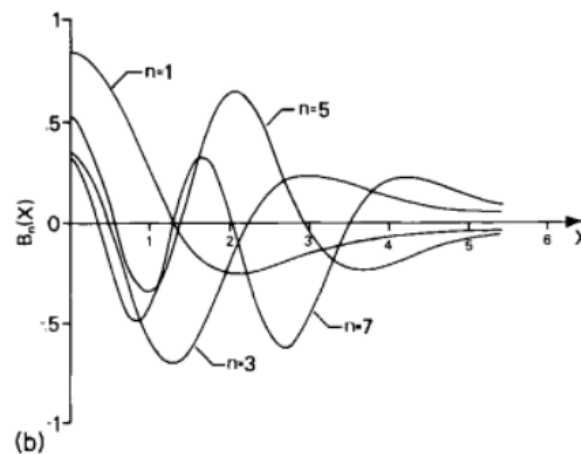
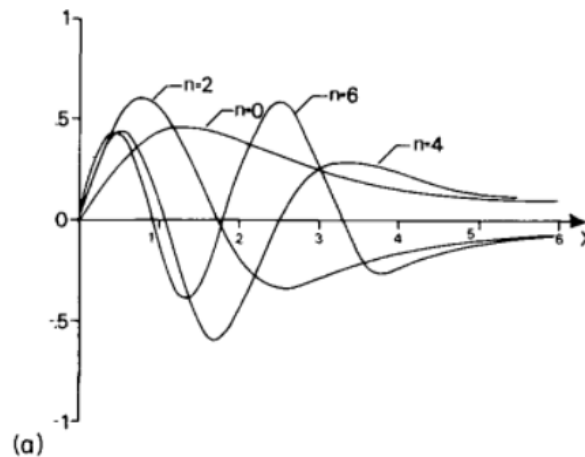
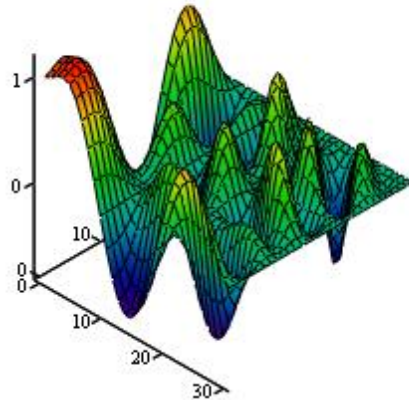

Figure 8.17 Even and odd Beranek functions $B_n(x)$, which are the Hilbert transforms of the Hermite functions. These are used for expansions of minimum-phase system functions.

Statistical Phase Analysis

$$\psi(x,y) = A \cos(1/4 k^2xy) + B \sin(1/4 k^2xy) + C \cosh(1/4 k^2xy) + D \sinh(1/4 k^2xy)$$



DEA ($kL=10$) Interpolation Function

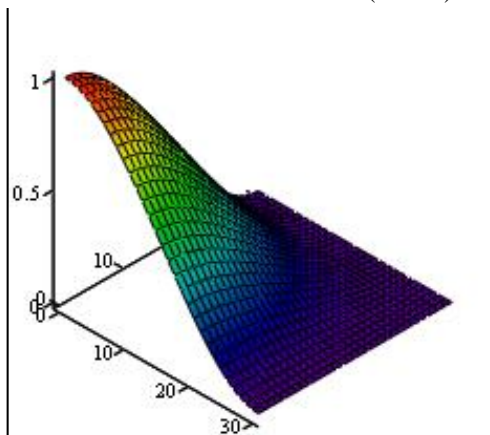

FEA Polynomial Interpolation Function

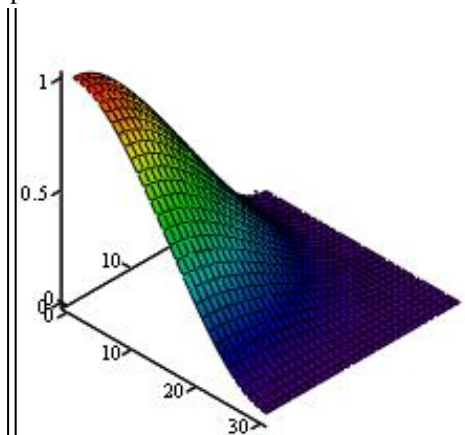

DEA ($kL=.01$) Interpolation Function

Statistical Phase Analysis

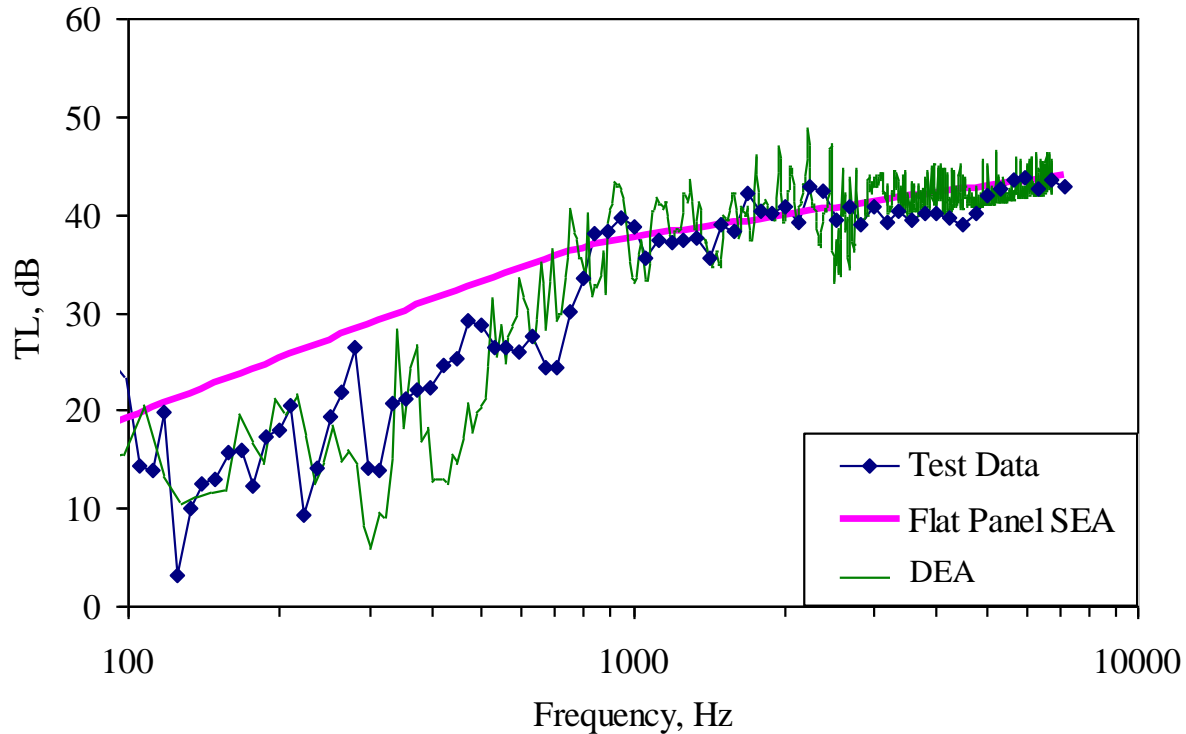
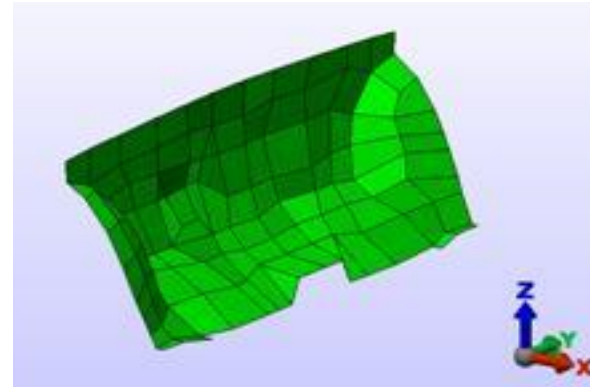

Lyon Statistical Mode Shape Functions

1D: $\psi(x) = A \cos(kx) + B \sin(kx) + C \cosh(kx) + D \sinh(kx)$

2D: $\psi(x,y) = A \cos(\frac{1}{4} k^2 xy) + B \sin(\frac{1}{4} k^2 xy) + C \cosh(\frac{1}{4} k^2 xy) + D \sinh(\frac{1}{4} k^2 xy)$

3D: $\psi(x,y,z) = A \cos(k^3 xyz/6\pi) + B \sin(k^3 xyz/6\pi)$

Hobbies



Hobbies





Response of Strings to Random Noise Fields
Richard H. Lyon, *J. Acoust. Soc. Am.* 28, 391 (1956)

Slides presented for Dick Lyon by daughter Kathy Davis.



Lake Michigan

Michigan

Illinois

Indiana

Ohio

Evansville

Kentucky





BENDAMIN - BOSSG
HIGH SCHOOL





MCMXVI

MASSACHUSETTS INSTITUTE OF TECHNOLOGY

MATTHEW LYON
Fair Haven's oldest mills
built on falls by founder
Matthew Lyon, Irish-born leading
grantee, built grist, saw, and
paper mills here, 1783, and a forge
above. He ran first store, inn,
and newspaper. As Congressman
from Vermont he was jailed under
the Sedition Law and later elected
from Kentucky and Arkansas.





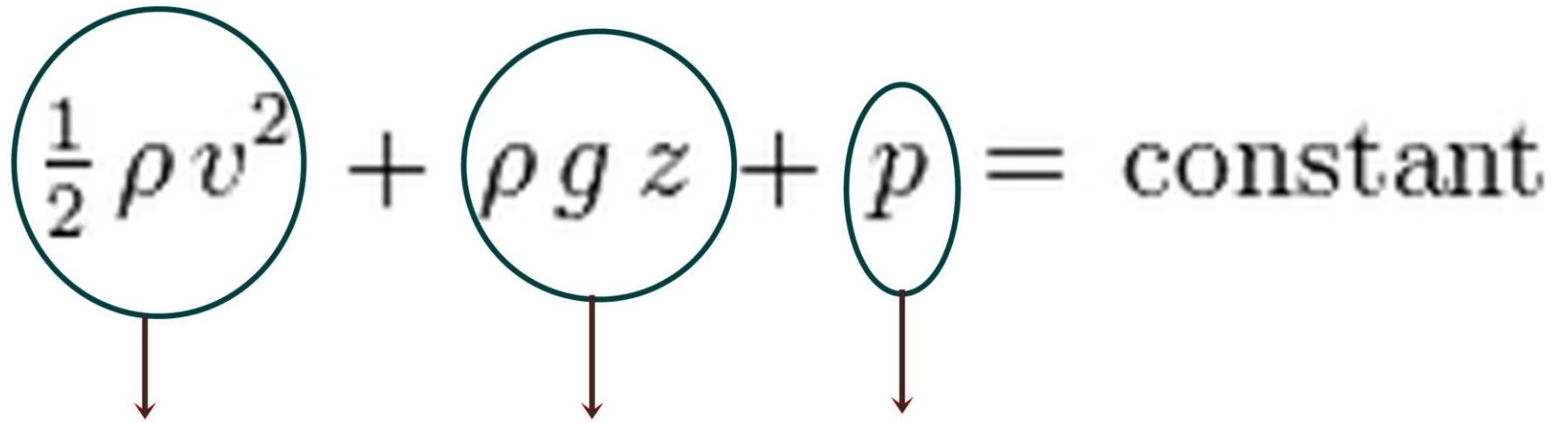

$$\frac{1}{2} \rho v^2 + \rho g z + p = \text{constant}$$
The diagram shows the Bernoulli equation with three terms circled in green. Below each circled term is a brown arrow pointing downwards to a corresponding label in blue text. The first term is $\frac{1}{2} \rho v^2$, the second is $\rho g z$, and the third is p .

kinetic energy

work done by weight

work done by pressure













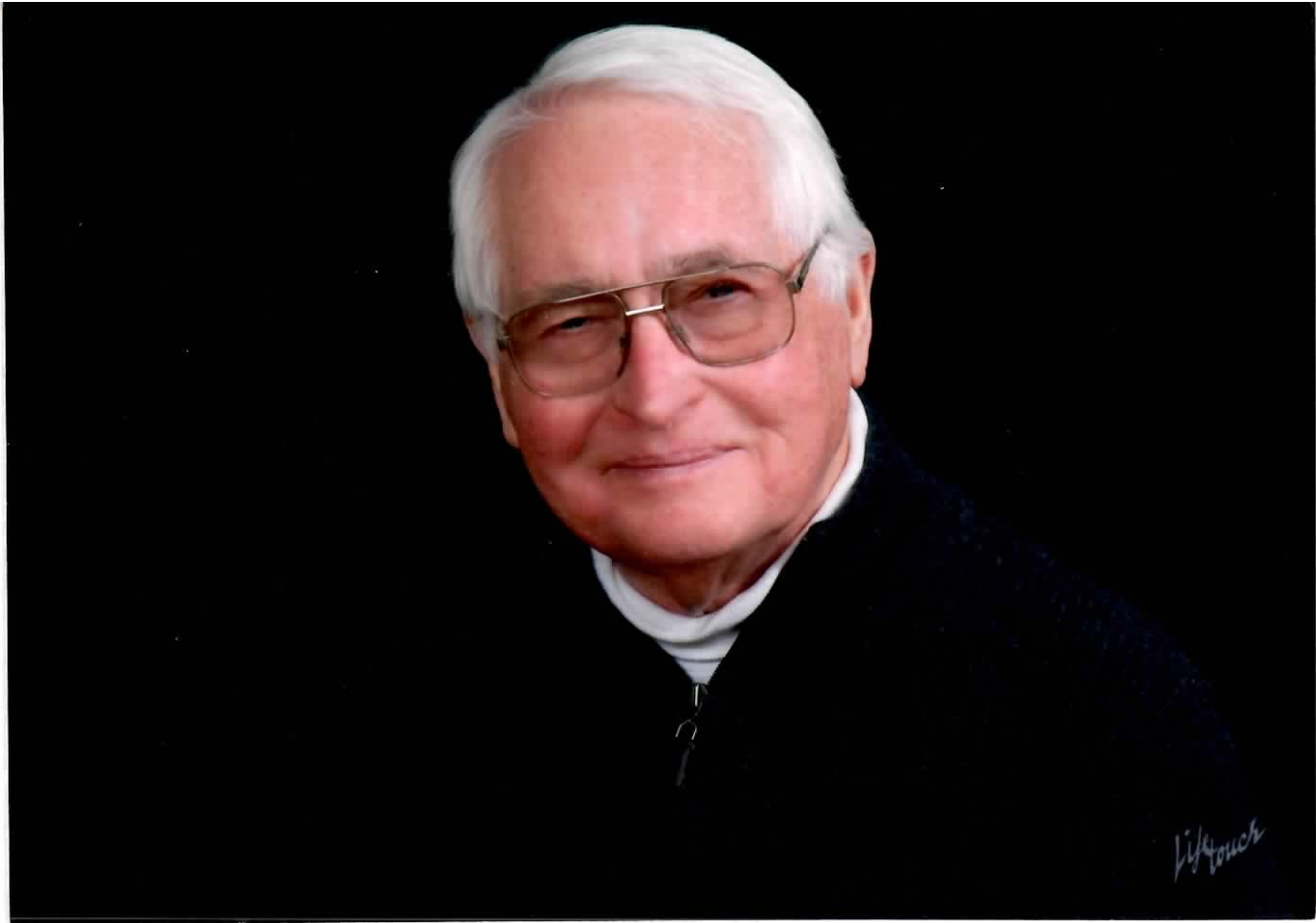

Eric Ungar Session Schedule

- 2:10 – 2:15 Introduction
- 2:15 – 2:30 Jeff Zapfe, President Acentech
- 2:30 – 2:45 Jim Barger, Chief Scientist Raytheon BBN
Technologies
- 2:45 – 3:00 Yoram Kadman, President Kadman-Berman Ltd.
- 3:00 - 3:15 Hal Amick, Vice President Colin Gordon Associates
- 3:15 – 3:30 Sharon Lane, daughter



Eric and Goldie at BBN



Eric and Goldie Enjoying Our Tea Party Last Summer



Four Lovely Ungar Daughters

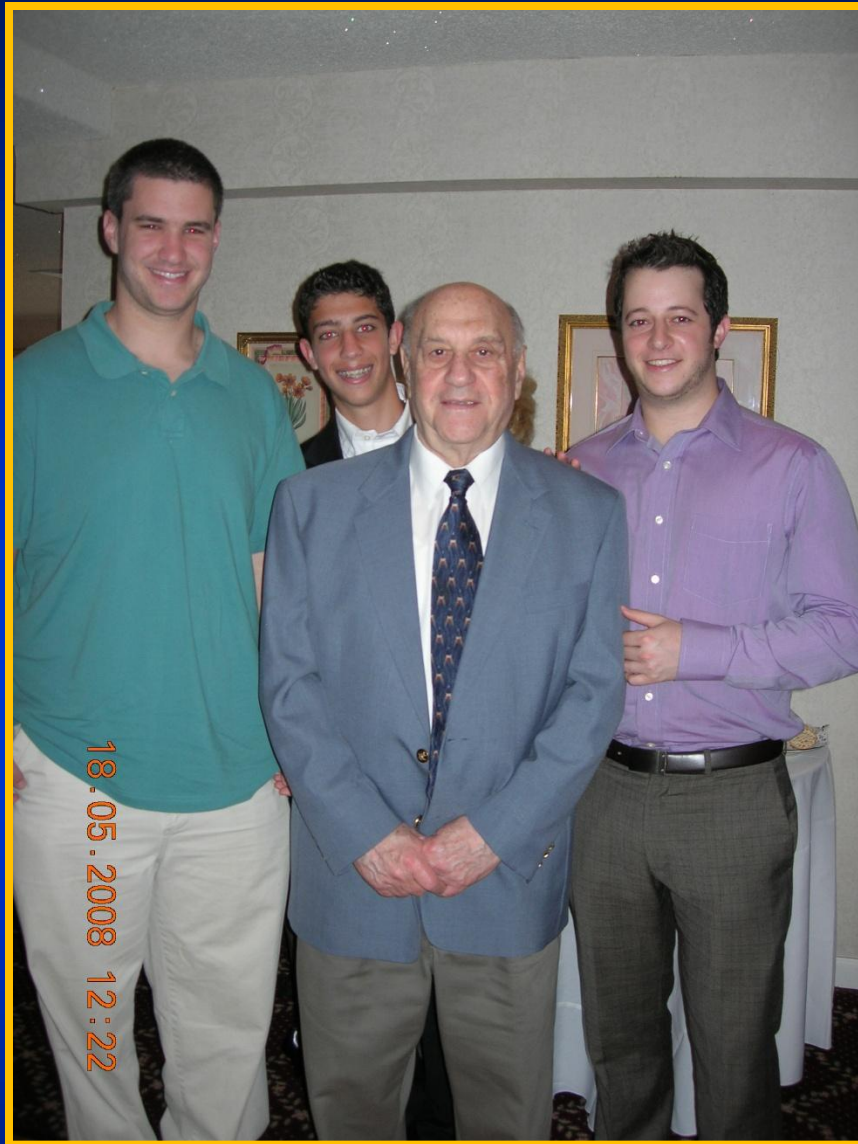

Eric with Grandsons



Eric with Grandchildren

Slides presented for Eric Ungar by Jeff Zapfe who serves as president of Acentech.



ACENTECH

A Tribute to Eric Ungar

NoiseCon 2016
June 14, 2016
Providence, RI





Eric Ungar





The Effects of Vibration Consulting





The Effects of Vibration Consulting





How Eric Got Here

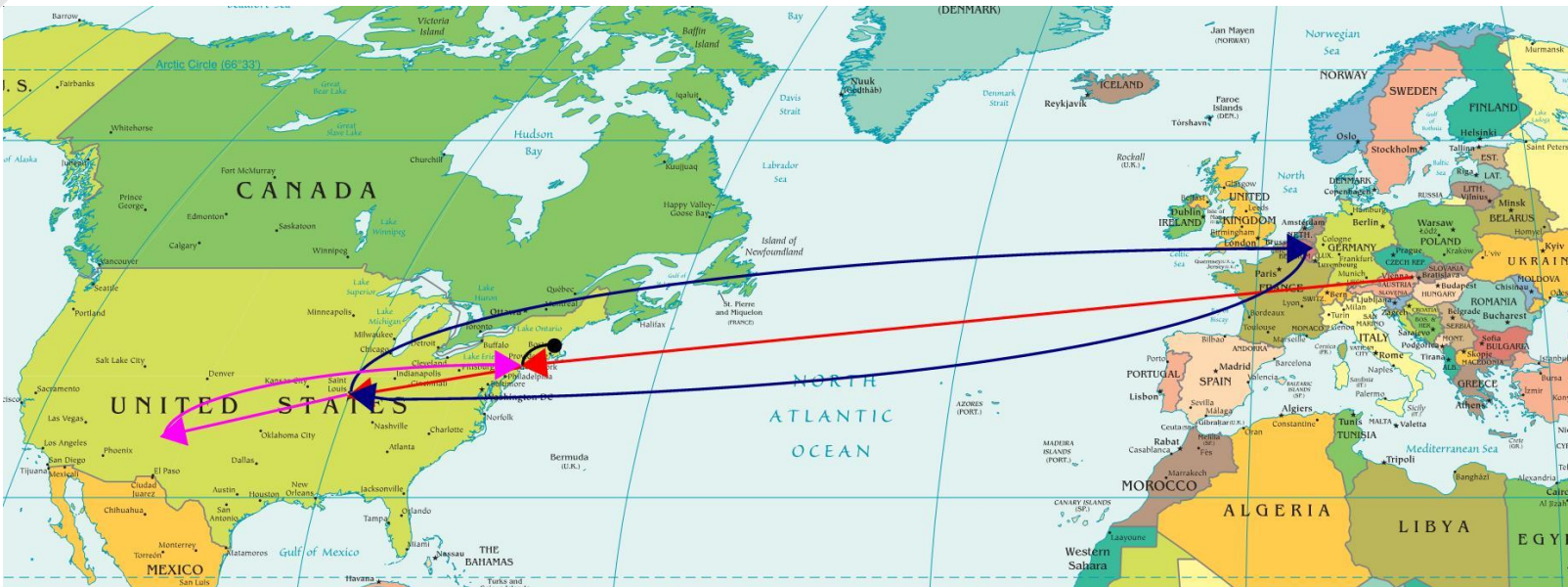



Research

- Early 1950's
- First JASA paper 1959
- Publications - lots





Guides and Courses

- Vibration Sensitive Facilities
 - Vibration Criteria (VC) Curves
- AISC Design Guide11
- Penn State Acoustics and Vibration Course
- Acoustics from A to Z



Paul Erdos

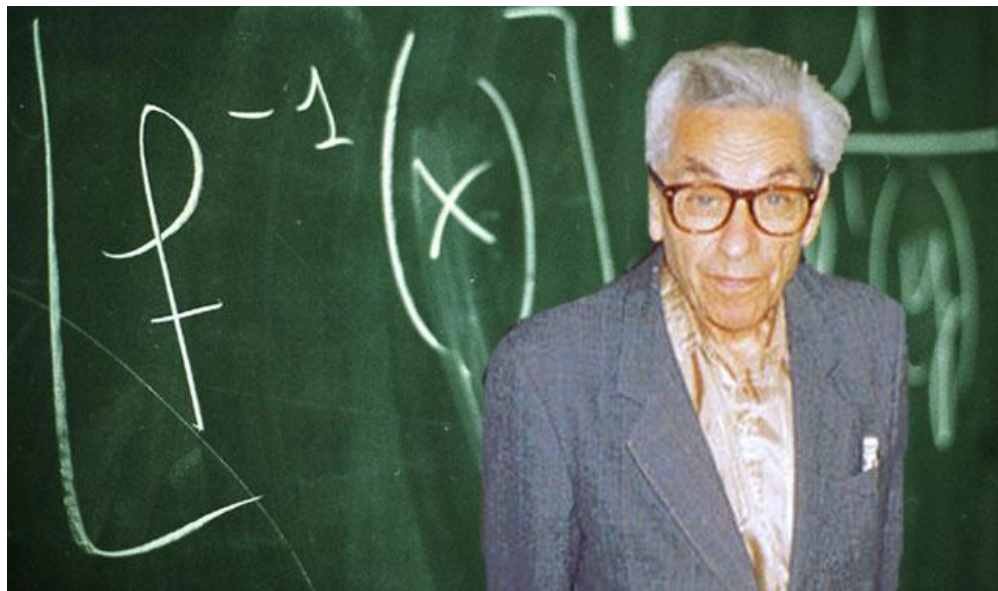



Research Areas

- Viscoelastic Damping
- Damping of Structural Joints
- Aeroacoustic Loading on Structures
- Vibration Mounts
- Rail Vibration
- Stiffness of Entrapped Air





Stiffness of Entrapped Air

Design of floated Slabs to Avoid Stiffness Effect of Entrapped Air
Noise Control Engineering, July-August 1975

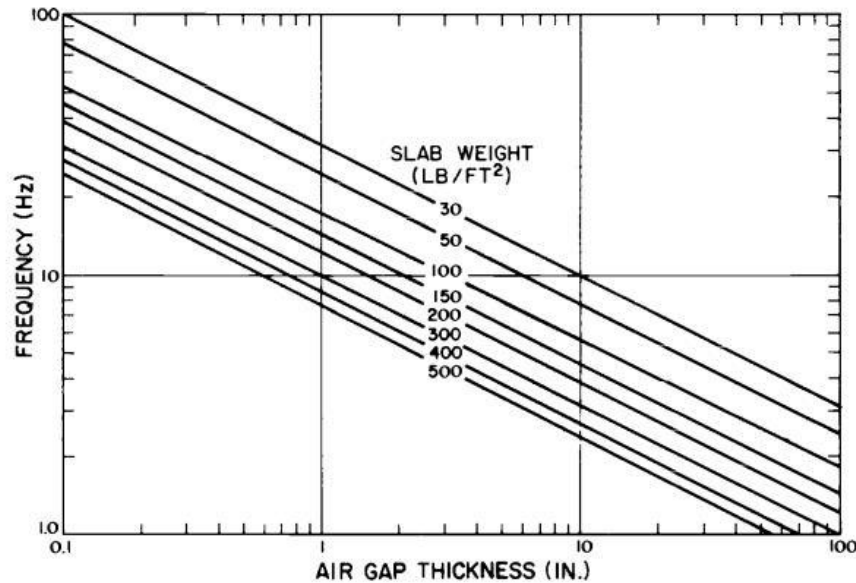



Vibration Propagation in Buildings

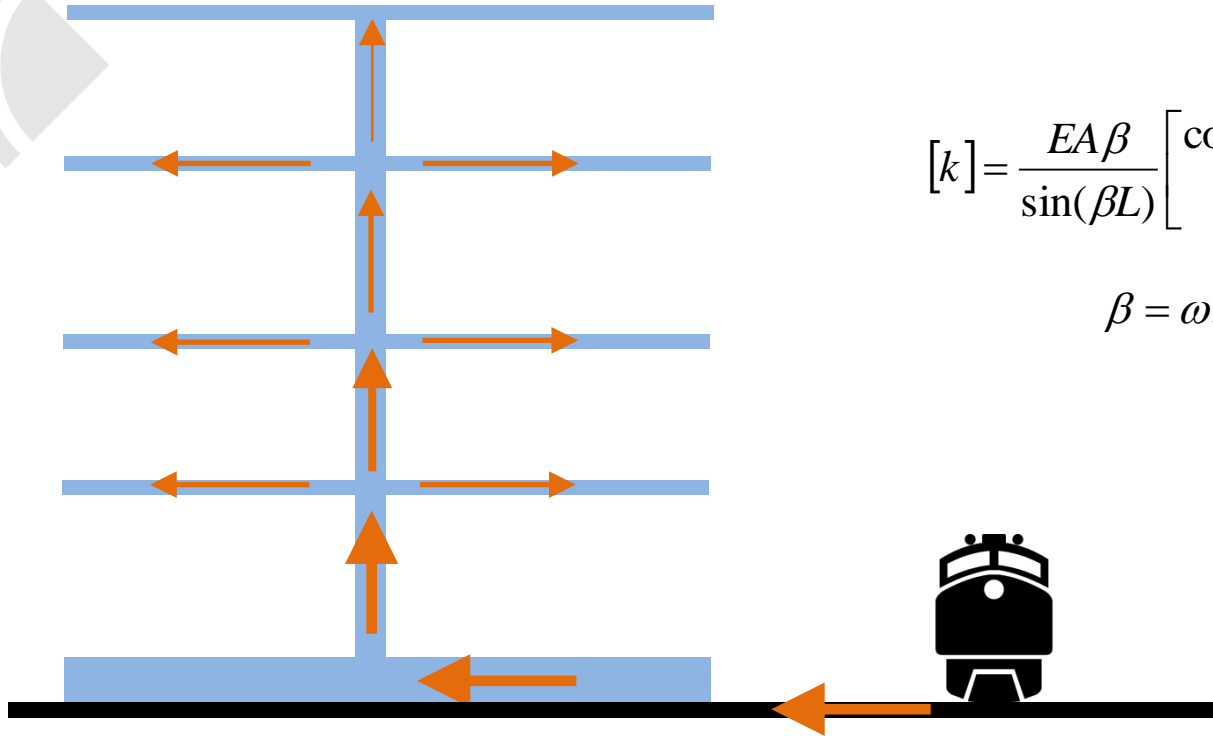

$$[k] = \frac{EA\beta}{\sin(\beta L)} \begin{bmatrix} \cos(\beta L) & -1 \\ -1 & \cos(\beta L) \end{bmatrix}$$

$$\beta = \omega \sqrt{\frac{\rho}{E}}$$





Biographical Listings

- American Men and Women of Science
- Who's Who in Aviation and Aerospace
- Who's Who in the East
- Dictionary of International Biography
- Who's Who in Technology Today
- Who's Who in Engineering
- Men of Achievement
- Who's Who in America
- Who's Who in the World
- Who's Who in Science and Engineering
- Biographical Directory of Occupational Health and Safety Specialist
- The International Who's Who of Contemporary Achievement
- International Who's Who in Engineering
- Personalities of America
- Who's Who in Consulting



Awards

- INCE, Board Certified Member, President (1985)
- ASA, Fellow, President (1992-93), Gold Medal (2011), Trent-Crede Medal (1983)
- ASME, Life Fellow, Per Bruel Gold Medal (1994), Centennial Medallion (1981)
- Associate Fellow, American Institute of Aeronautics and Astronautics

Words presented about Eric Ungar for Jim Barger former vice president, division director, and chief scientist at BBN.

Eric Ungar at NOISE CON

James Barger
May 27, 2016

Jim Barger invented, developed, and demonstrated an extraordinary number of innovative acoustic systems and devices. Many for the Defense Advanced Research Projects Agency and the U.S. Navy. Some have served to help protect our country. Jim is unable to attend today in person. He is here in spirit. I will read the words that he provided:

I was a newly commissioned Ensign, USN, starting duty in 1957 at the United States Navy Underwater Sound Laboratory in New London, CT. I had found on my Midshipman cruises that sonar didn't work very well, and I wanted to do what I could to fix that problem. Most of the civilian staff at USNUSL were electrical engineers, and they explained to me that the main problem hearing echoes was masking by electrical shot-noise, originating in vacuum tubes. It sounded like turbulent flow to me. I set about performing experiments designed to elucidate this idea. My commanding officer agreed to pay my way to the Acoustical Society of America meeting where I was to deliver a paper on my TBL experiments if I were to join the society.

Subsequently I attended every ASA meeting, and read the Journal. I found that there was a small group of engineers at a place in Cambridge called Bolt Beranek and Newman that seemed already to know a lot about what I was trying to learn: Ira Dyer, Preston Smith, Dick Lyon, and Eric Ungar. I corresponded with all members of this group, and made several trips from New London to Cambridge to pick their brains. These early interactions with Eric and his colleagues convinced me that physics is more interesting than the Naval career that I had planned.

To improve my math and physics abilities I left active duty at the end of my UNUSL tour and enrolled in Physics at Harvard, with Ted Hunt as my advisor. Leo Beranek had been his first PHD student, and once I became one of his last, I started work at BBN.

The first project that I worked with Eric had to do with understanding sound radiation from an elastic plated excited by turbulent boundary layer pressure fluctuations. I put together the partial differential equations and their boundary conditions, but I asked Eric to solve them. He did so in a very short time, but I was slightly disheartened to see that he had

solved the equations by infinite series. It seemed it would take forever on a calculator to turn Eric's solutions into numbers that the client needed. Fortunately, BBN took delivery at that time of PDP 1, serial No. 1. This was the first computer delivered by the Digital Equipment Corporation, and the first digital computer designed for scientific calculations, rather than for accountant's arithmetic. I found someone to program Eric's series, and we pumped out everything our client (ONR) needed in a short time.

My interests drifted away from consulting towards R and D. Eric's interests drifted toward consulting. I remember that one of his clients was the company that had the contract to design the METRO in Washington D.C. Eric consulted in particular with his client on the proper way to isolate train-induced ground vibration from neighboring structures. The METRO authority held many hearings with abutters along the proposed rights of way. One of these interested parties was Murray Strassberg, a very competent, but contrarian, physicist who worked at the David Taylor Model Basin. I knew Eric was in trouble when Murray told me how he had figured out how BBN's (Eric's) analysis could be challenged, and how he proposed to do just that. I would guess that Eric has some

residual memory of the fuss that Murray caused. After this, the President of BBN, Steve Levy, got the idea that many of our noise-control consulting clients were too heavily lawyered-up. He decided to divest of our acoustical consultants. This idea led to the formation of Acentech.

Eric left BBN then and went across the street with Acentech. Fortunately, he continued to eat at the BBN cafeteria, and so it didn't seem as if he had left. Nevertheless, our professional interactions ground slowly to a complete halt – until May 2011, when I received from the ASA a Silver Medal at the same meeting that Eric received the Gold Medal.

I am grateful to Eric Ungar, Ira Dyer, Preston Smith, Dick Lyon, and Leo Beranek for enticing me to join with them at BBN 52 years ago. The whole BBN experience was, I'm certain, much more exciting than the Naval career I'd planned for.

Text of presentation for Eric Ungar by Yoram Kadman. Yoram served as a Senior Engineering Scientist at BBN for ten years after which he returned to Israel. He is now president of Eco Environmental & Acoustical Engineering Limited. He continues providing consulting and litigation support services in the areas of environmental noise and vibration control.



SAFE AND SOUND
Environmental & Acoustical Engineering

Honoring Eric E. Ungar Noise-Con 2016 Providence, R.I.

14 June, 2016

Yoram Kadman

Y. Kadman - Y. Berman

ECO - ENVIRONMENTAL & ACOUSTICAL ENGINEERING

71 HANADIV ST. HERZELIA 46485, ISRAEL Tel. +972-9-9587119 Fax +972-9-9574629

www.eco-eng.co.il office@eco-eng.co.il

Honoring Eric E. Ungar

It is 50 years, almost to the day, since I first met Eric. You must appreciate that these were gentler and simpler times and much more normal.

I was a semi-wild nature boy from Israel and at the end of my first graduate year at MIT the dean of foreign students sent me for a summer job to an obscure company called BBN.

The appointment was at early June of 1966 and all my career advisors insisted that this was a business meeting and I have to go dressed with a suit – including a jacket and a tie.

You have to realize that I did not wear a suit even for my wedding and my wife complains, until this day, that the meeting with Eric was more important to me than my wedding.

That June day was very hot and there I was, dressed for a funeral, walking among the young crowds of Cambridge, all dressed in torn jeans and T-shirts.

By the time I found the address I was close to fainting.

By the time I was waiting in the BBN lobby I was sure that I will die from the heat and the choking of the tie, and then Eric came out and saved my life. As I remember, his first words were:

YOU CAN TAKE OFF YOUR TIE AND YOUR JACKET.

I was a mechanical engineer straight out of the classroom and my knowledge of acoustics and vibrations was very sketchy and limited to Den Hartog's course in MIT.

I started my apprenticeship under Eric and as I learned later, this was a career, and to a degree, a life changing experience. I found out that I was not the only one so affected by the pleasure of working with and under Eric.

The first job he assigned to me was to determine the minimum distance allowed between a rogue Atlas rocket and the mission control building before the rocket should be destroyed. I had not the faintest idea on how to approach the subject but Eric – gently and slowly – guided me and showed me how to start, how to

define the problem and the tools that I should use in the solution. Needless to say he wrote the final report – longhand – and managed to give me the good – but somewhat false feeling that I did a good job.

Those days – before the PC and the word processor - Eric would sit in his office and write reports in a very neat handwriting and in orderly fashion, with almost no correction and erasures and the professional and logical progression of his work were of the highest quality.

This clarity and knowledge made him a superb teacher, author and lecturer and indeed many engineers – including myself – still turn to his lectures, course notes and books whenever we are faced with a sticky problem.

Eric contributed to almost every handbook that deals with vibration and damping. He translated to English the classic book of Cramer and Heckel - Structure-borne Sound - and I am proud to have an autographed copy that he sent me which I regularly consult.

His professional authority was certainly enhanced by the fact that he is built like a tank and has a black belt in Karate for many years.

We spent in Boston 11 years and some of our fondest memories are my friendship with Eric, Goldie and the daughters and the Friday evening dinners at the Ungars.

Every now and then a small sample of the vast Ungar family visits us in Israel and the bond now extends to the third generation.

Eric is also the Godfather of my youngest son – who is now 40 years old.

I don't have to delve into the Eric's contribution to our professional organizations – his award of many medals and testimonials are evidence of his deep involvement with the advancement of our profession.

Eric is a standard bearer of our society, a pillar of the community and a rock to his family.

As the bible said about Moses:

"HIS EYE IS UNDIMMED AND HIS VIGOR UNABATED".

Eric defined clearly his views on the role of the consultant:

My consultant is my shepherd; I shall not fail.

***He enableth me to dream of green pastures,
to be calm like still waters.***

***He restoreth my faith; he leadeth me in the paths of efficiency,
for my project's sake.***

***Yea, though I walk through the valley of the shadow of doubt,
I will fear no failure for he adviseth me;***

His help and his staff's, they comfort me.

He prepareth tables before me in the presence of mine personnel,

He anointeth my head with ideas;

My cup runneth over.

Surely success and progress shall follow me

all the days of my work and

I will dwell in debt to my consultant forever.

So, Eric, for being a scientist, an engineer, a friend and mentor and all around real **MENTCH** – Thank you!

Slides presented for Eric Ungar by Hal Amick who serves as vice president of Colin Gordon Associates located in Brisbane, California.

Generic Criteria: a Lasting Legacy

(a tribute to Ungar & Gordon, NoiseCon 2016)

Hal Amick, PhD, PE

Vice President

Colin Gordon Associates

Eric Ungar has contributed many great things to engineering, quite a few of them as a collaborator. This presentation is about one of those contributions, one which keeps evolving with the times and growing in popularity ... Generic Criteria

Generic Vibration Criteria (1/2)

- 33 years ago, Eric Ungar and Colin Gordon of BBN gave us the notion of generic vibration criteria
- Analogous to NC criteria for noise
- Could be used to design vibration-sensitive facilities
- Design for types of instruments or scale of work rather than specific instruments

Decades ago, during the infancy of semiconductors and the world of “computer chips,” Eric Ungar at BBN Cambridge and Colin Gordon were being approached by makers of semiconductors and designers of cleanrooms for help controlling vibrations. As engineers, they needed a design objective. They joined forces to collect the existing criteria published by manufacturers in an attempt to define a common thread to use for design. They gave us what we now call the generic vibration criteria.

They are analogous to the NC criteria for noise in spaces, in that they are somewhat independent of the specifics upon which they are based. They are based on what is going to be done in a facility, rather than upon the specific brand and model of equipment it will be done with. Presumably, if an instrument is going to work with relatively large features on a chip, it might be relatively insensitive to vibration. On the other hand, if it is working with smaller features, it will be more sensitive to vibration. Those two features defined the beauty of the generic criteria: categories of instruments rather than specifics, and geometry size.

Generic Vibration Criteria (2/2)

- Brief look at their story
 - Genesis
 - 1983-85
 - Evolution
 - 1985-2005
 - Where are we now?
 - Common usage
 - Multiple publications
 - AQAP – How quiet is now possible?

In this presentation, we will review the history of the generic criteria, from their creation and first publication in the early 1980s, to where we are now with their usage. Because of how Eric and Colin set them up, the criteria were able to evolve with the changing needs of technology.

Now, in their fourth decade, they are the most commonly used form for defining and assessing criteria in the technology environment, and have been published in multiple venues.

Now we who practice vibration control for tech environments wrestle with the design goal some clients give us, which some define with an acronym: AQAP: As Quiet as Possible. How quiet is now possible?

1983-85 – First “Public” Views

- “Vibration Challenges in Microelectronics Manufacturing,” (Elias Klein Memorial Lecture), Eric E. Ungar and Colin G. Gordon, *Journal of Shock & Vibration*, May 1983
- “Vibration Criteria for Microelectronics Manufacturing Equipment,” Eric E. Ungar and Colin G. Gordon, *Internoise 83*, 1983
- “Cost-Effective Design of Practically Vibration-Free High-Technology Facilities,” ,” Eric E. Ungar and Colin G. Gordon, presented at ASCE 1985 Spring Convention in Denver, Colorado

Eric and Colin started working with these facilities and collecting data in the late 70s and very early 80s. They shared what they had found with their peers in three seminal papers in 1983 and 1985. The 1983 papers define the complexity of working with the criteria provided by manufacturers. The last of the three gives the initial form of the criteria we know today.

(A few months after the 1985 paper was given, Hal Amick returned to BBN Cambridge, eventually being attracted into Eric’s orbit to begin what became his passion.)

1983

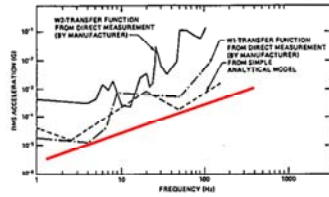

Fig. 1. Floor acceleration criteria for two photolithography devices, developed from transfer functions.

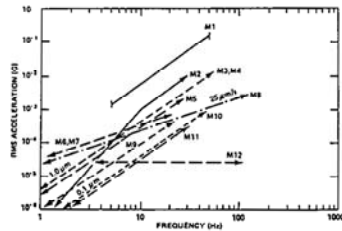

Fig. 2. Suppliers' floor vibration criteria for twelve different electron microscopes. (Arrows at end of lines indicate criterion stated without frequency restriction.)

- Papers only showed the complexity of the problem
- Each instrument had its own vibration requirements
- Variety of formats, variety of sophistication
- Clue of where they were to go was in Fig. 1 (red line added by me)
 - Constant velocity (red line) is lower bound

These figures from the 1983 papers illustrate the complexity of designing to manufacturers criteria. The top figure shows criteria for photolithography instruments for chip making, all with the same objectives. The bottom one shows criteria for electron microscopes of similar capabilities. The question they faced was: “How do we design a facility for these? For an individual instrument? Or for all of them?”

Their solution is suggested by the red line, which Hal has added. It is the lower bound of the set of photolithography instruments in the graph. It is also a line representing velocity on this acceleration spectrum: one decade per decade, or 6 dB per octave.

1985

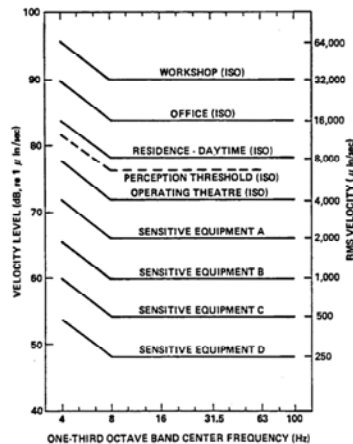

- Generic criterion curves introduced, denoted A, B, C and D
- Each one defined the lower bound (most demanding requirements) of a group of instruments
- Shapes based on ISO Threshold of Perception
- Defined as rms velocity in 1/3 Octave Bands
 - Flat over most of their range
 - Defined only for f between 4 and 100 Hz
 - Relaxed below 8 Hz

With some finessing, the final product was ready for prime time in 1985, with the generic curves as given in the 1985 paper. The dashed line represents the human threshold of perception, as given as the baseline curve in ANSI and ISO standards. The three curves above it and the one just below are from those standards. Borrowing the same shape, Ungar and Gordon extended the shape downward in 6 dB steps creating four new criteria, which they denoted by letters, A, B, C and D.

Continuing with the ANSI and ISO tradition, they defined the curves in terms of one third octave bands. They elected to use velocity rather than acceleration because most of the significant vibration in facilities was between 10 and 100 Hz, and the criterion shape was flat in this range, and thus more compact visually.

Two key features became problematic in a few years:

1. They were undefined below 4 Hz, and
2. They were relaxed below 8 Hz.

1985 - 1990

- Ungar explained *why* 1/3 octave bands were used
 - Good compromise between “too much” and “too little” data in spectra
 - Represented how a damped system with 10% damping combined energy
 - Good way to combine tonal and broadband representation (which are both present in facilities)
- Curves became known as “BBN Curves”
- Curve E added, at $\frac{1}{2}$ the amplitude of Curve D

The next five years were somewhat stable, and the criteria gained acceptance.

Eric gave us some explanations as to why the 1/3 octave bands were useful over other options, such as narrowband or PSD representation

Eventually, one of the more problematic aspects of 1/3 octaves became the fact that non-acousticians started working with the criteria. Structural engineers had no idea what this meant, because it had no place in the basic civil or structural dynamics education. Hal Amick was able to sympathize. He was originally a structural engineer, and had to learn acoustics jargon.

Because the two creators were both with BBN and used the curves on BBN projects, the curves became popularly known as the “BBN Curves”. In many instances, the graphs were labeled “BBN-A” and so forth.

Toward the end of the decade, as semiconductors approached the magic “1-micron” feature size, Curve E was added, which was 6 dB below Curve D. The family of curves seemed complete.

1990

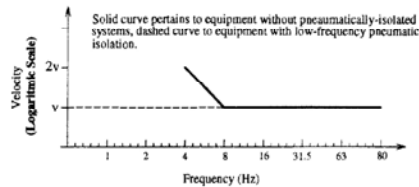

- Ungar proposed a shape change
- Accommodates equipment with internal pneumatic isolation
 - These instruments have sensitivity between 1 and 4 Hz due to airspring resonance
- Gordon introduces “VC” designation to replace “BBN” when Acentech separates from BBN
 - Borrowed from “NC” abbreviation, stood for “Vibration Criterion”

In 1990, two key things occurred.

Colin Gordon left BBN to form his own firm near Silicon Valley, and

Eric Ungar and two of his younger colleagues, Doug Sturz and Hal Amick (mostly Eric, though) published another paper about the criteria.

In the Ungar, Sturz and Amick paper, Eric introduced the notion of removing what had come to be called the “knee” at 8 Hz, extending the curves as a flat line down to 1 Hz. By this time, many of the most sensitive instruments were incorporating internal pneumatic isolation, and their greatest vibration sensitivity was then at frequencies below 8 Hz, often below 4 Hz. In the original form, the criteria were either relaxed or undefined at the airspring resonance.

It was quite a while before this change actually appeared in a publication, though consultants from both the Ungar school and the Gordon school were applying the flat form in practice.

Shortly after Colin left, he published a paper in which he replaced the “BBN” designation with “VC” based upon the “NC” for “noise criteria”.

2005

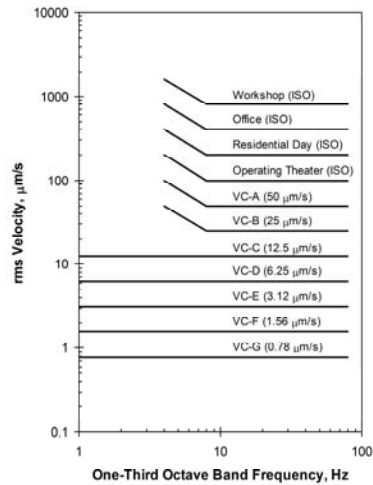

- Conference: *Buildings for Nanoscale Research and Beyond*
- “Evolving criteria for research facilities,” Amick, Gendreau, Busch & Gordon
 - Additional curves proposed (down to VC-G)
 - First actual publication of “flattened” spectra, VC-C and below

Jumping ahead to 2005, Hal Amick introduced a slightly spruced up version of the criteria in a paper at a conference.

It was metric.

It showed the flat version of the more stringent curves, from VC-C on down, and the version with the knee for Curves A and B, because microscopes and other less sensitive instruments without airsprings actually did behave that way.

It added new curves, following the Ungar and Gordon scheme of 6 dB steps and iteration of letter designation.

The original intent was simply to add VC-F as a means to characterize measurements that were “below VC-E”. The idea actually came from a couple of clients. It made some sense, and it also made some sense to add one more below that to accommodate “even quieter than VC-F” measurements, if they turned up. The intent at that time was not to use them as design goals.

AQAP

- Facilities for nanoscale research, imaging, and materials science have “nudged” the edge of the envelope
- Sometimes building requirements are “as quiet as possible” (AQAP)
- How quiet *is* possible ??

The world of nanotechnology and advanced materials introduced us to the notion of “as quiet as possible” in terms of vibration and acoustic criteria.

Researchers wanted environments in which neither of these variables would act as spurious variables in their experiments. They didn’t know how quiet it needed to be, just that they didn’t want the results to skew their experiment.

By the way, we were using this acronym before it was coopted by world security to refer to a terrorist organization.

We knew that theoretically, there was no such thing as “zero vibration,” but we didn’t really know how quiet was possible, or achievable, or economically practical.

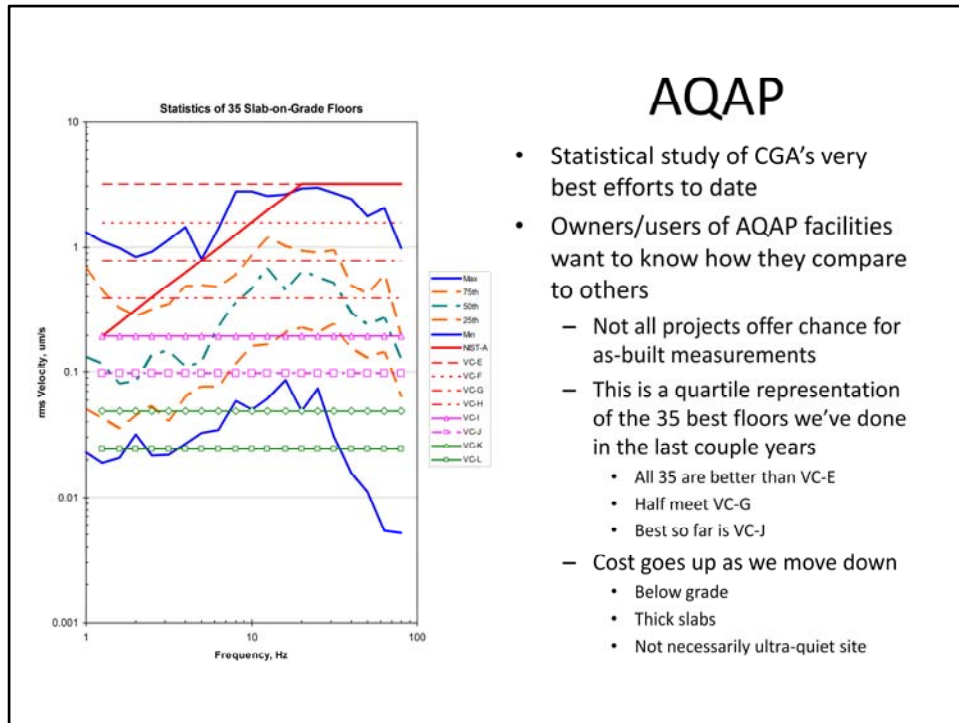

AQAP

- Statistical study of CGA's very best efforts to date
- Owners/users of AQAP facilities want to know how they compare to others
 - Not all projects offer chance for as-built measurements
 - This is a quartile representation of the 35 best floors we've done in the last couple years
 - All 35 are better than VC-E
 - Half meet VC-G
 - Best so far is VC-J
 - Cost goes up as we move down
 - Below grade
 - Thick slabs
 - Not necessarily ultra-quiet site

Hal Amick and his colleagues at CGA have designed and evaluated 36 slab-on-grade floors, many of which had AQAP as a design goal.

Some were in rather challenging environments. A couple are in cities.

Several are in basements. The deepest is two stories below surface elevation. (Several at this depth.)

Some employ thick slabs. The thickest is 2 meters.

In order to answer the question, "How does my floor compare with other AQAP floors?" a statistical study was done of the measured performance of the 36 floors. The results are shown here in terms of the four quartile regions, along with progressively more stringent VC curves.

Some of the ones that appear less impressive actually involve impressive attenuation of a challenging site.

All 35 are better than VC-E

Half meet VC-G

The best so far is VC-G.

The cost generally increases as we move downward

The main variables are:

1. Going below grade
2. Thickened slabs

Published in Many Places

- Conference Proceedings
 - Too numerous to name
- “Official” Publications
 - AISC Design Guide 11 (Ungar a co-author)
 - ASHRAE Fundamentals
- Standards Documents
 - IEST RP-12 “Considerations for Cleanroom Design” (Amick on working group)
 - IEST RP-NANO207 “Measuring and Reporting Vibrations in Advanced Technology Facilities” (in preparation, Amick chair)

The Ungar and Gordon criteria have been published in many places. Some are shown here

The Legacy

- Uncountable facilities designed to the Ungar & Gordon generic criteria
 - Semiconductor
 - Flat Panel
 - Nanotechnology
 - Bioscience
 - Vivaria
 - Imaging
- The *de facto* standard for vibration-sensitive facilities
- Originally curves A to D
 - Curves D and E are routine goals
 - Now seeing specifications down to curve G
- In 1985 resolution and line widths were a few micrometers
- In 2016, imaging resolution is sub-Angstrom and line widths are a few tens of nanometers
- Driving efforts to design facilities meeting much better than VC-E

Probably a thousand facilities have been designed to this family of criteria, used by the majority of consultants doing consulting on these facilities

The *de facto* standard

When the criteria were created, feature size (called “line width” in semiconductors) was on the order of a few micrometers (called “microns” at the time)

By 2016, imaging resolution is sub-Angstrom, and line widths are a few tens of nanometers

Intel and other chip makers put their collective foot down and said they wouldn't continue to build facilities to increasingly stringent criteria because of the costs involved. They would continue building their facilities to VC-E or VC-D, and the equipment manufacturers had to “live with it” and solve it internal to the machine

Nobody told the nanotechnology and imaging folks. FEI is now routinely specifying VC-F and VC-G for some of their more demanding electron microscopes.

Thank you

- Eric E. Ungar
 - Collaborator
 - Mentor
 - Engineer, Researcher
 - Editor
 - Scholar
 - Man of Great Integrity and Honor

Thank you for listening

Thank you to Eric Ungar for being such a great collaborator, mentor, consultant, and all the other hats he's worn.

In particular, we are thankful to have know a man of such great integrity and honor.

István L. Vér Session Schedule

- 3:30 – 3:35 Introduction
- 3:35 – 3:50 Nelson Kiang, Founder and Former Director
Eaton-Peabody Laboratory
- 3:50 – 4:05 Michael Roark, Burns & McDonald
- 4:05 – 4:20 Kevin P. Shepherd, NASA Langley Research
Center (ret)
- 4:20 – 4:35 Jim Barnes, Principal Consultant Acentech
- 4:35 – 4:50 Marika Ver

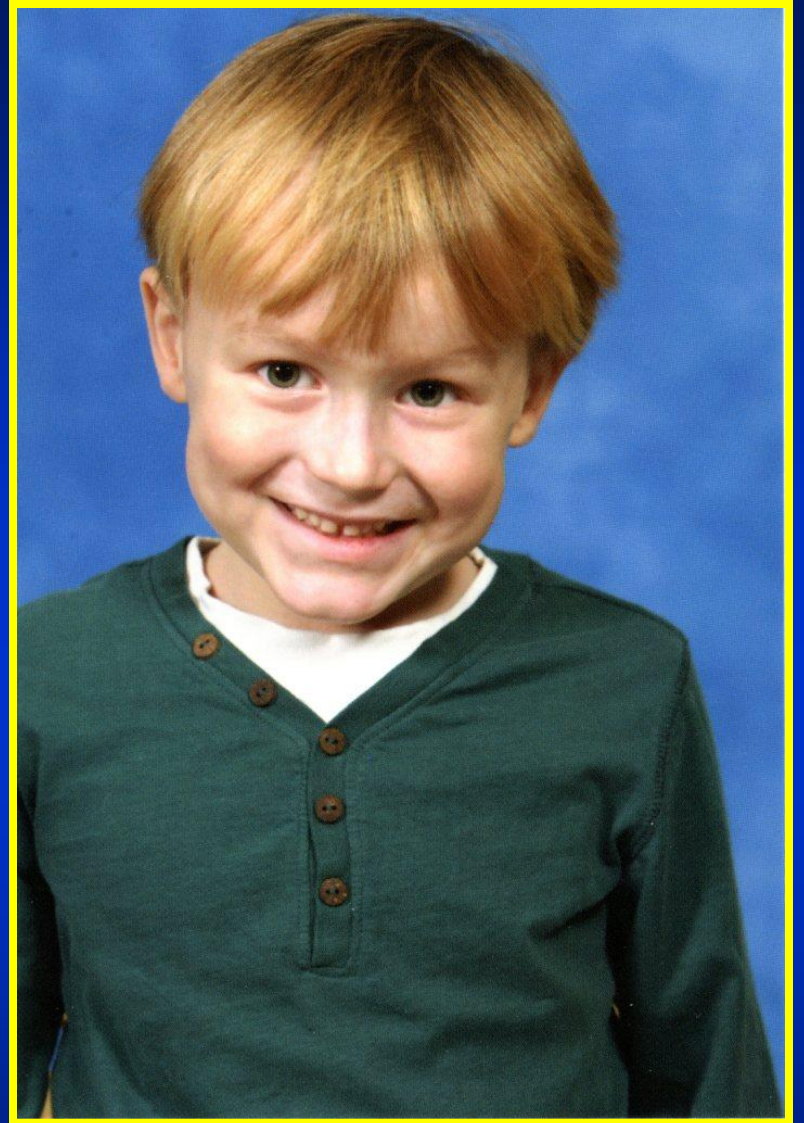
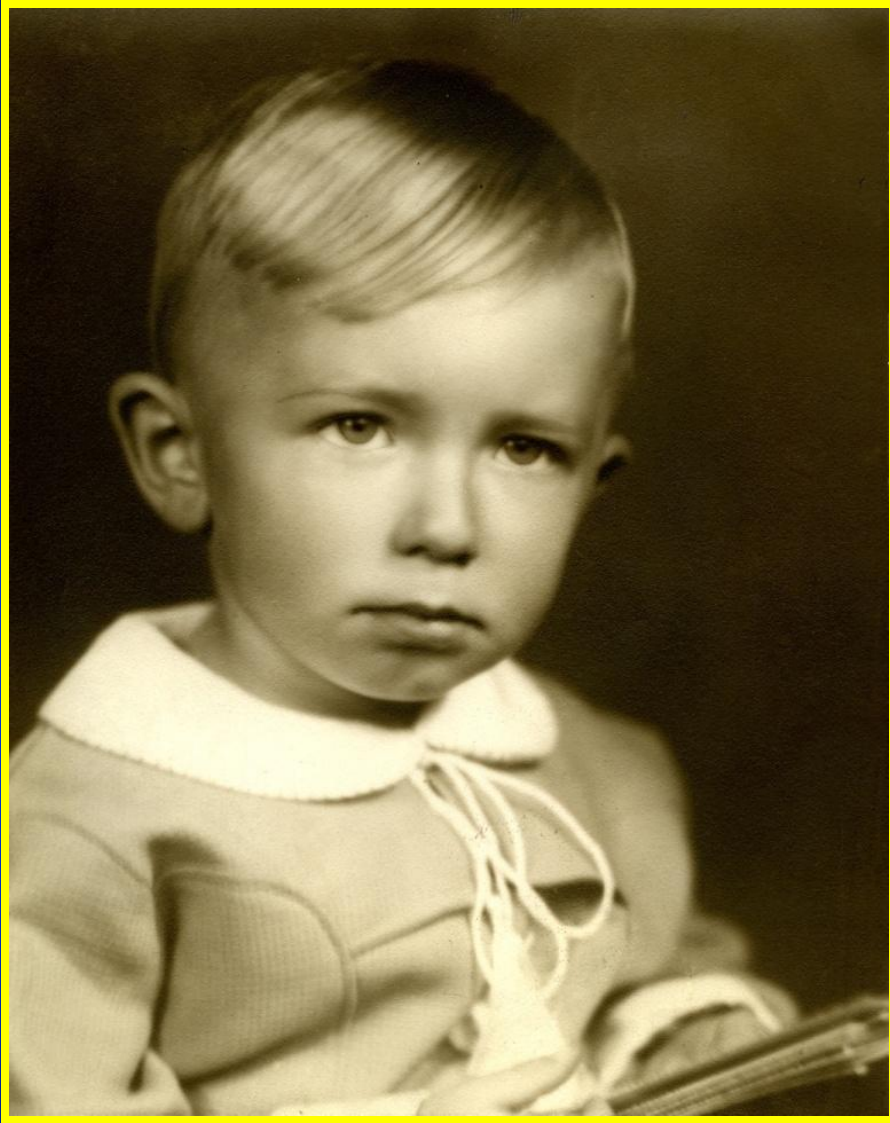

Younger Istvan



Istvan and Marika (formal and less formal)



View from their Lakeside Home



Afternoon Lakeside Party



Istvan's 80th Birthday Party with Brenda Wood

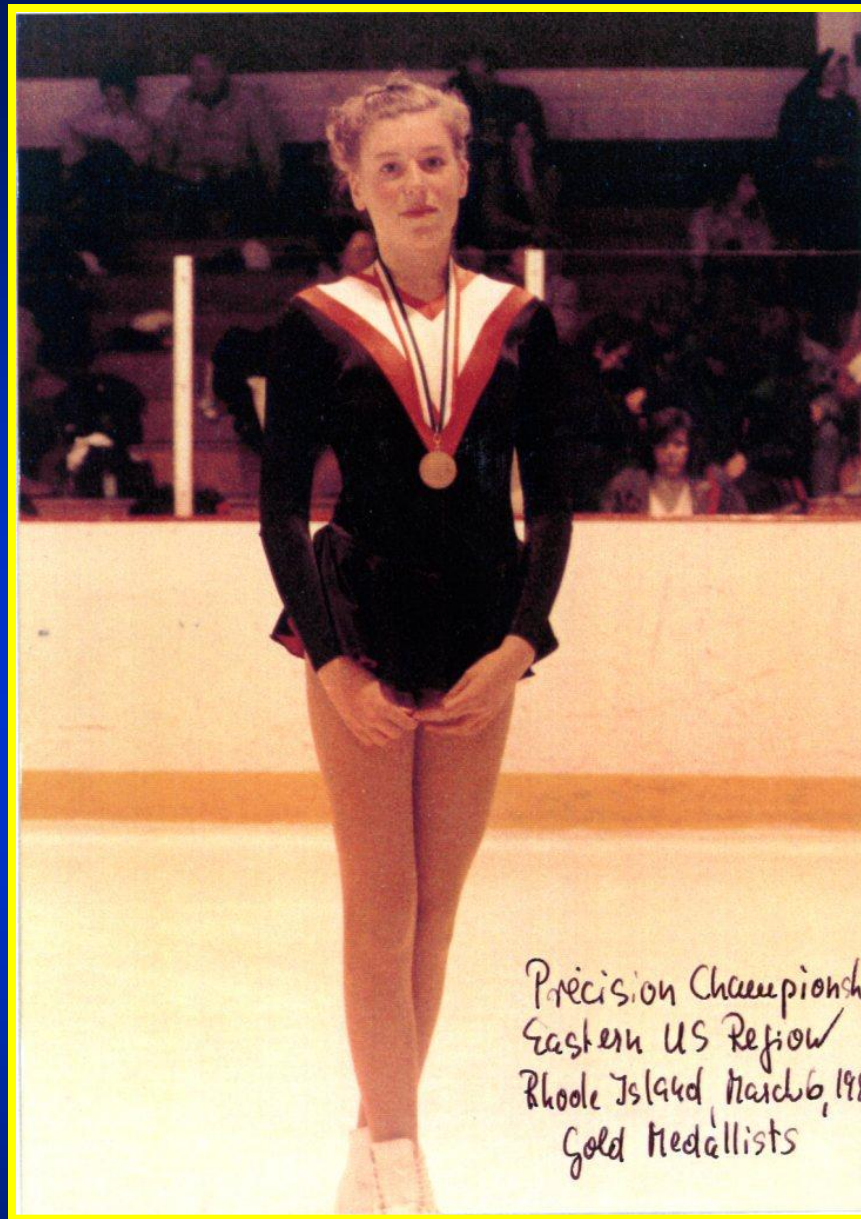

Daughter Kristina during Precision Championship Event



Istvan at Wedding for Daughter Kristina August 2005



Grandson Rowan from Daughter Kristina (2007)



Istvan and Jet Engine Exhausts

Slides presented for Istvan Ver by Nelson Kiang founder and former director of the famous Eaton-Peabody Laboratory jointly operated by Harvard, MIT, the Massachusetts Eye and Ear Infirmary and the Massachusetts General Hospital.

“István L. Vér and the Eaton-Peabody Laboratory”

Nelson Yuan-sheng Kiang

Institute of Noise Control Engineering Conference

Providence, Rhode Island

June 14, 2016

- I. Designing Low-Noise Chambers
 - A. Requirements
 - B. Solutions

- II. Using the Chambers
 - A. Physiological Experiments
 - B. Chamber-Raised Animals
 - C. Pathophysiology of Acoustic Trauma
 - D. Efferents

- III. Implications for Noise Control

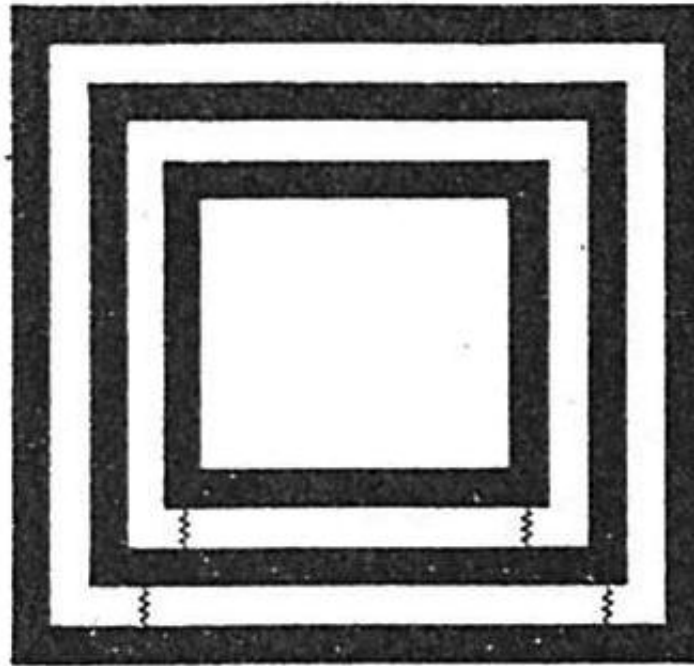

Design concept for the chambers
(Vér, Brown & Kiang, 1975)

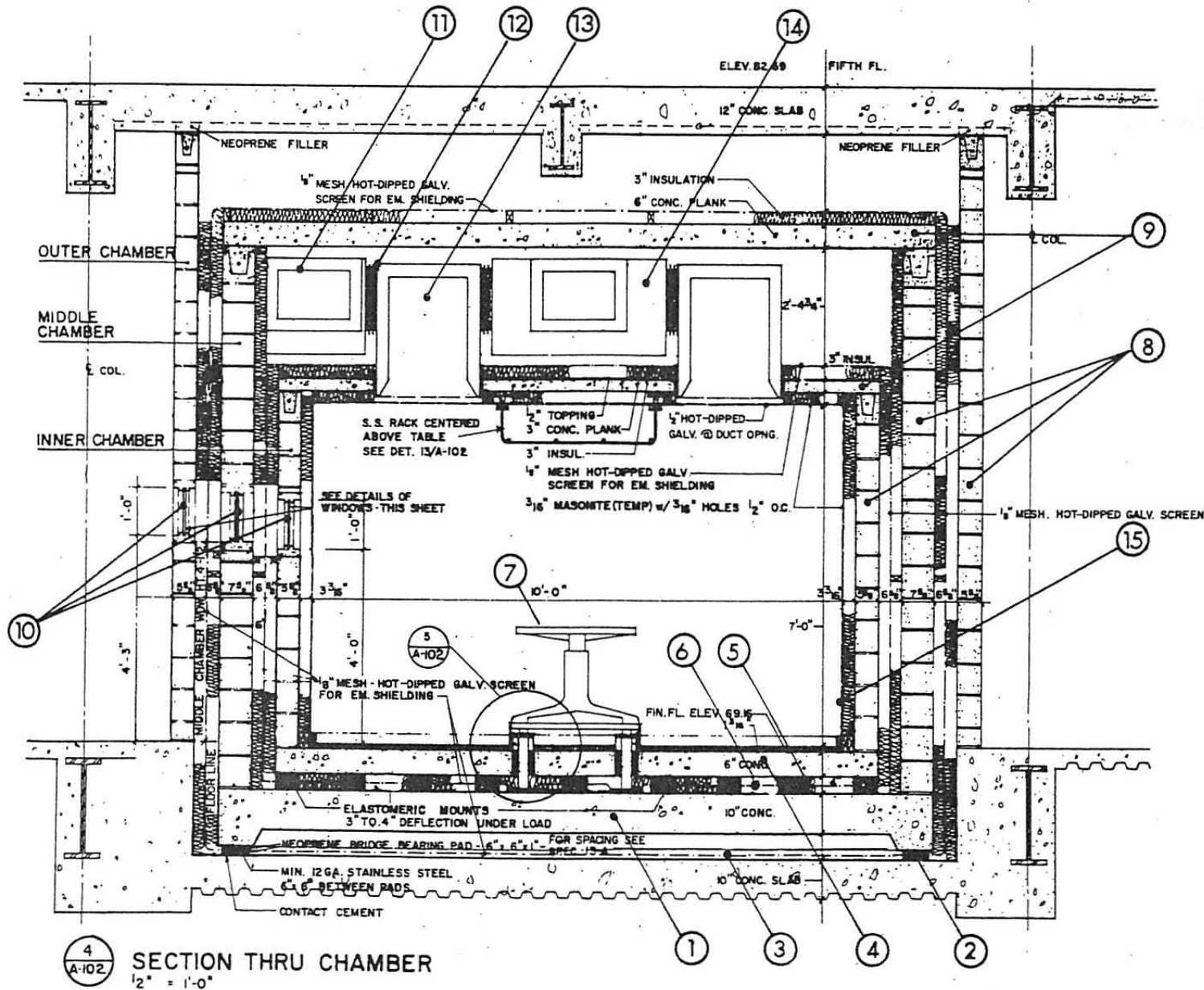

Vér, Brown & Kiang, 1975

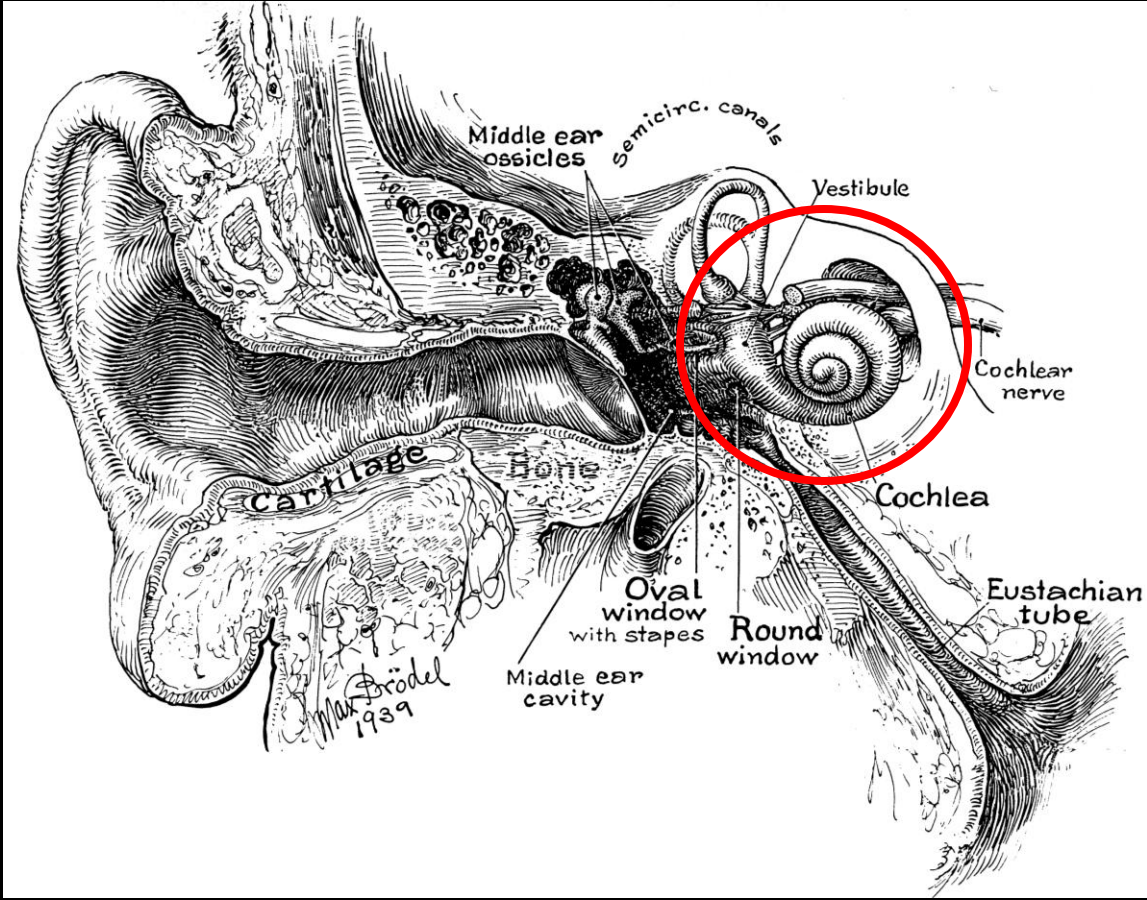

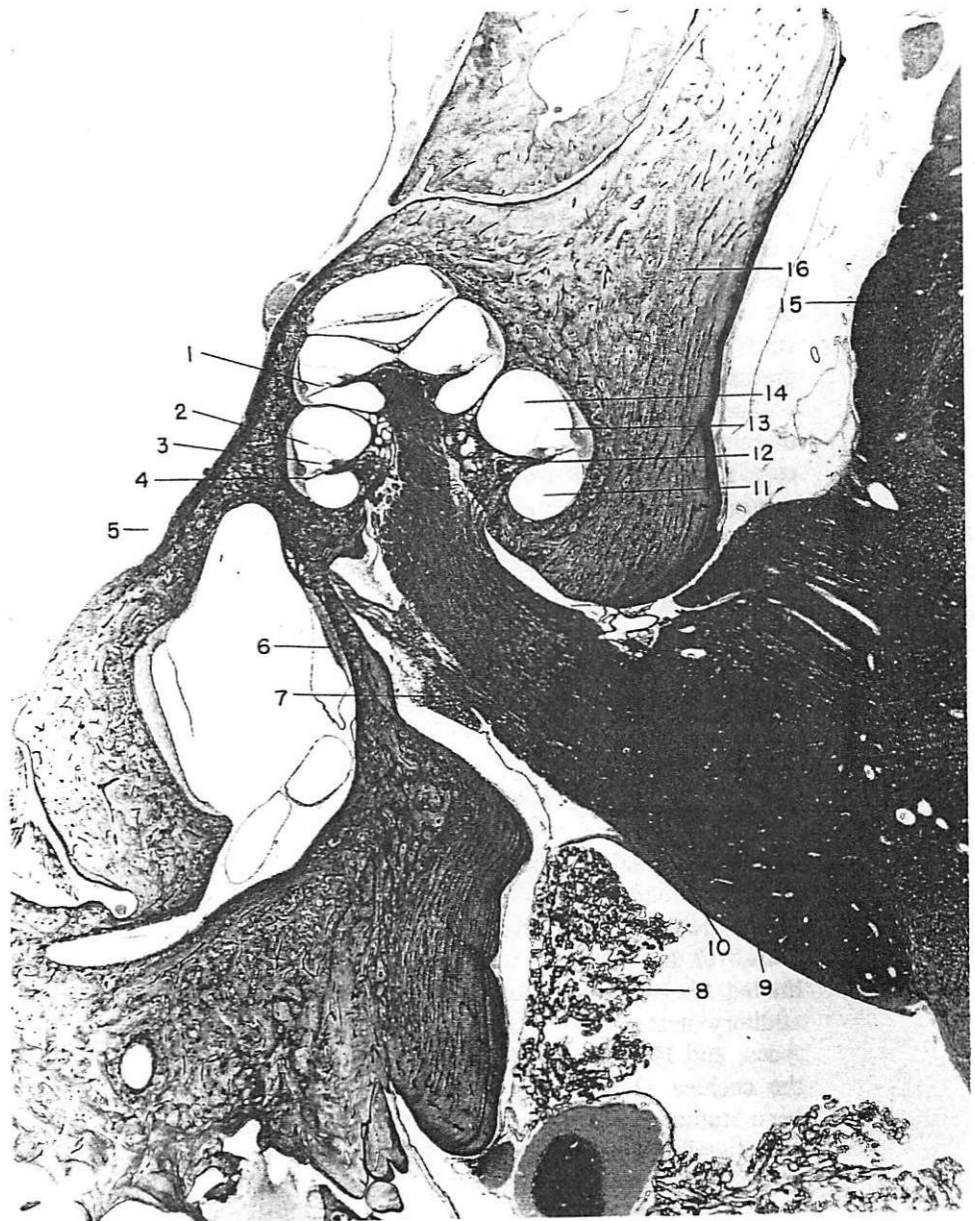

Kiang, 1965

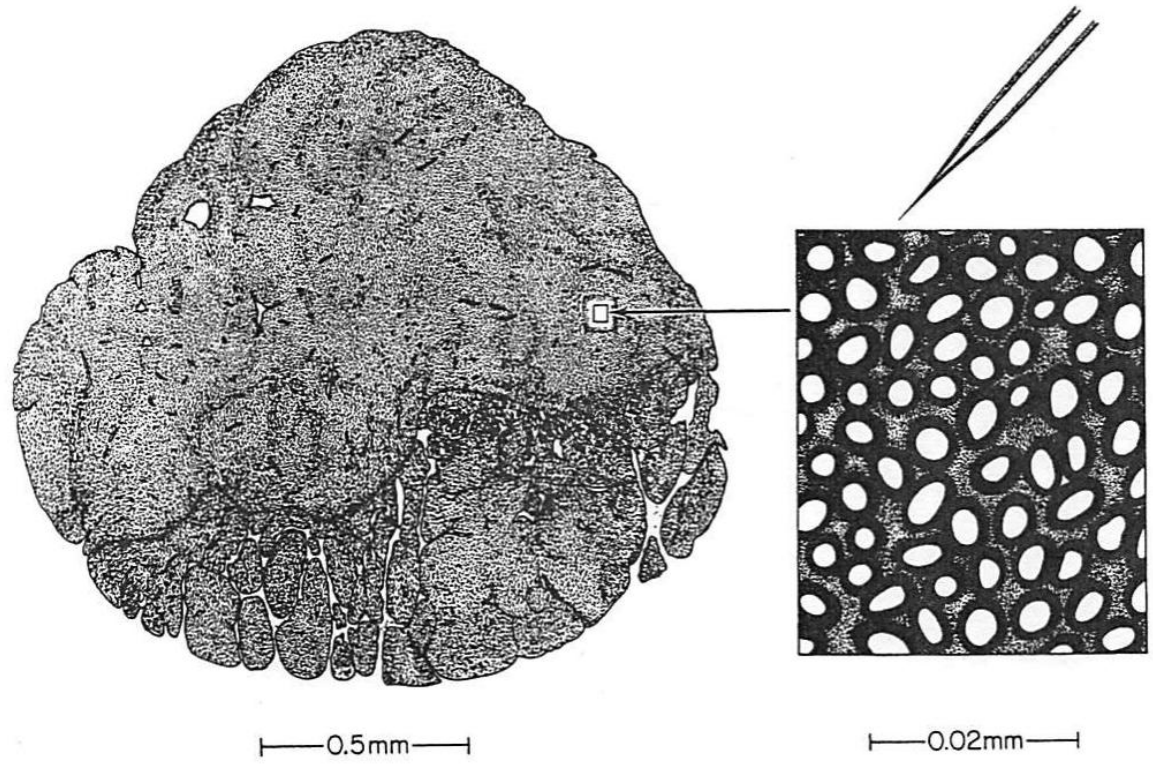

Kiang, 1984

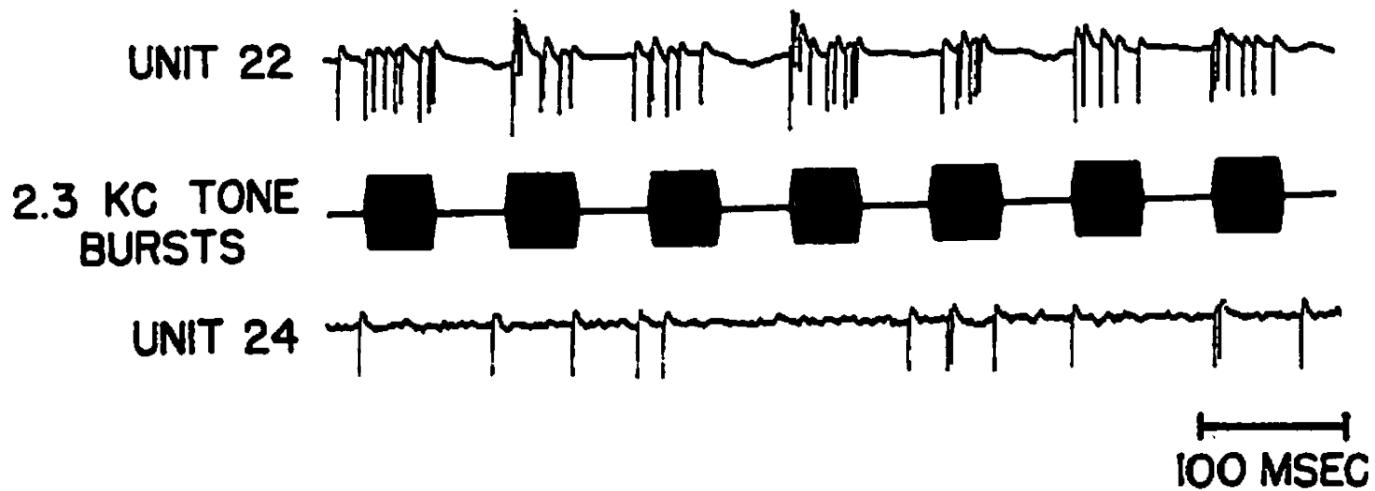

Spike Trains from 2 Auditory Nerve Fibers in Response to 2.3 Hz Tone Bursts
(Kiang, 1965)

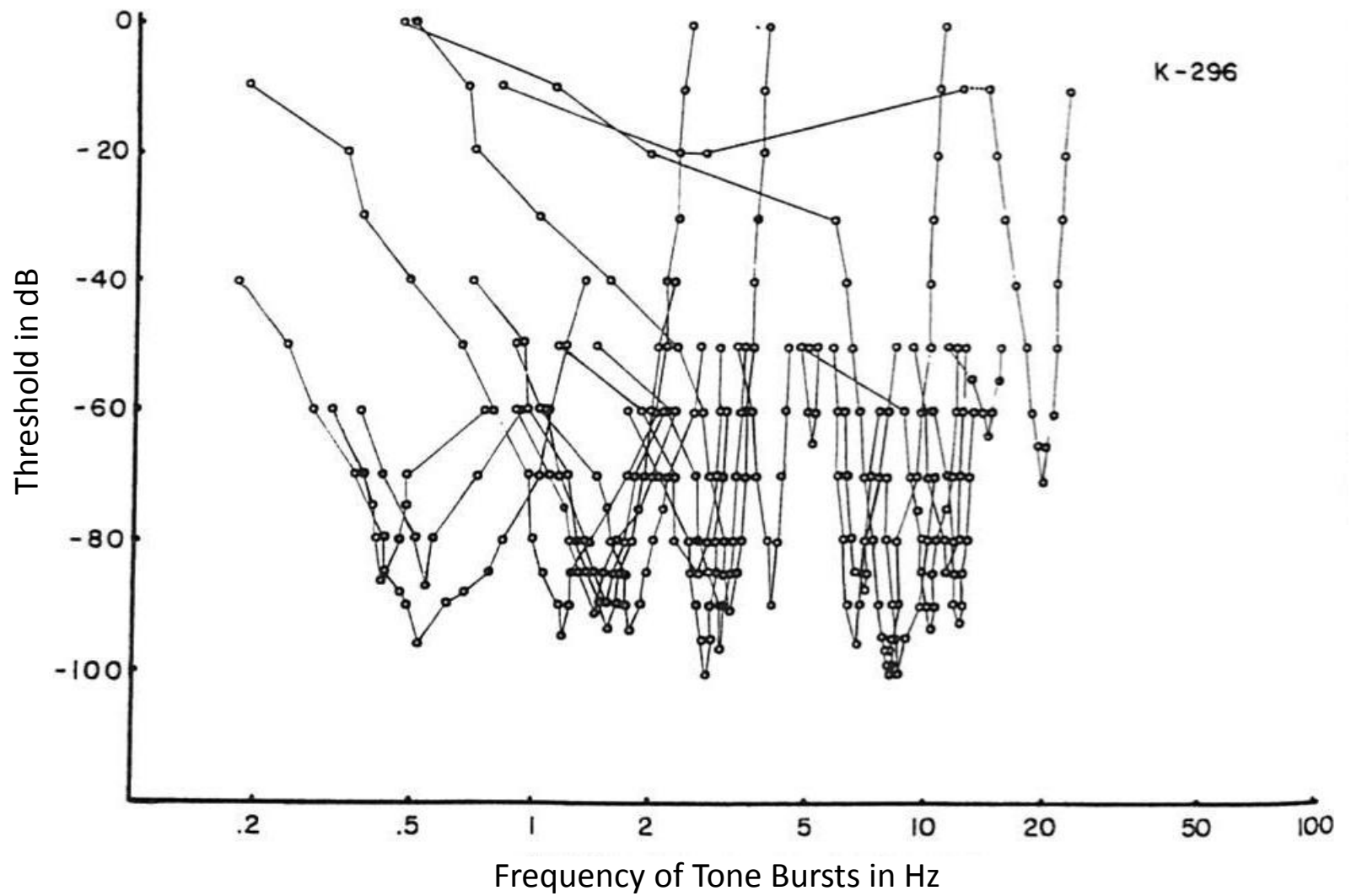

Tuning Curves from One Cat (Kiang, 1965)

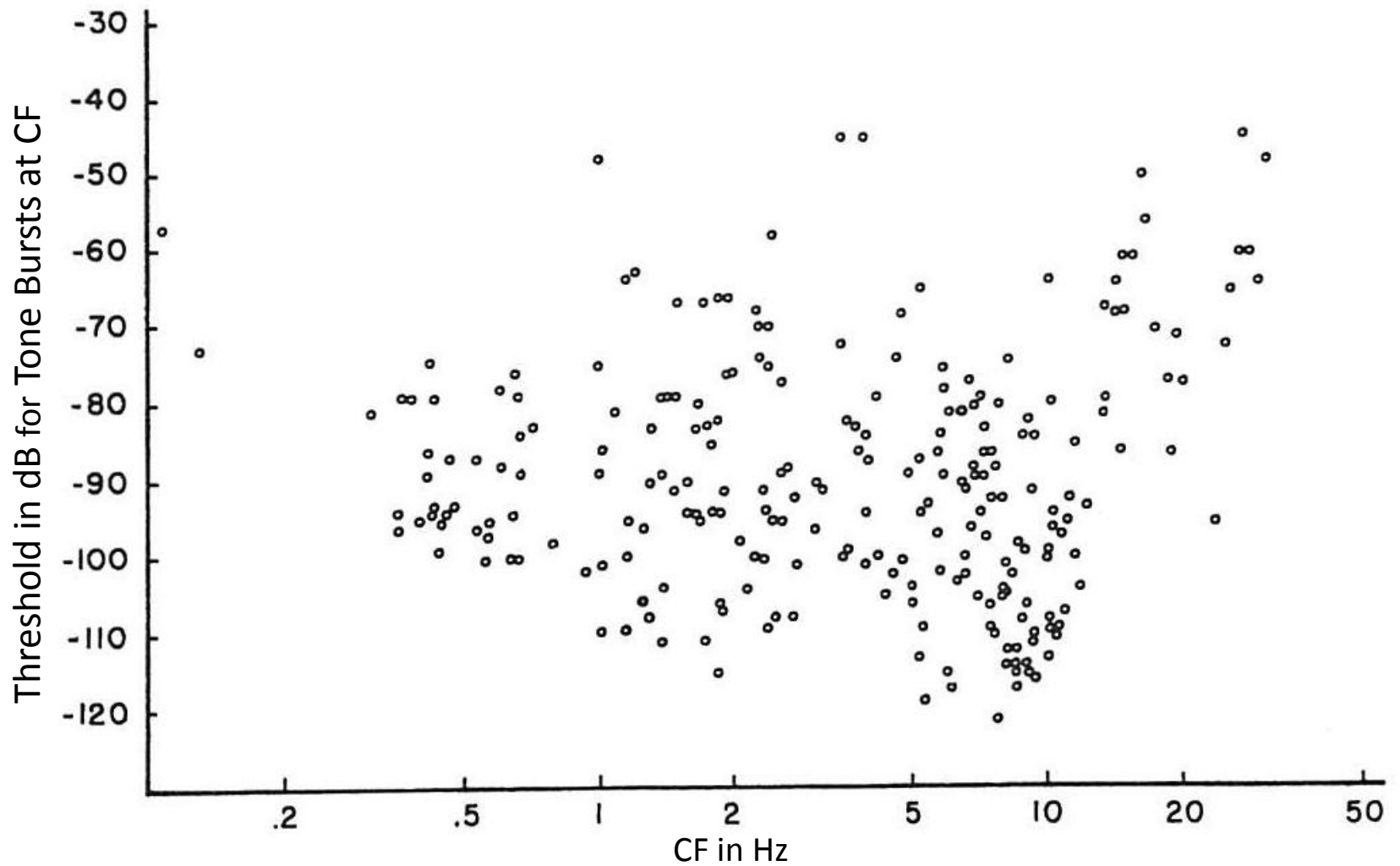

Data from 12 cats (Kiang, 1965)

SPONTANEOUS ACTIVITY



Kiang, 1965

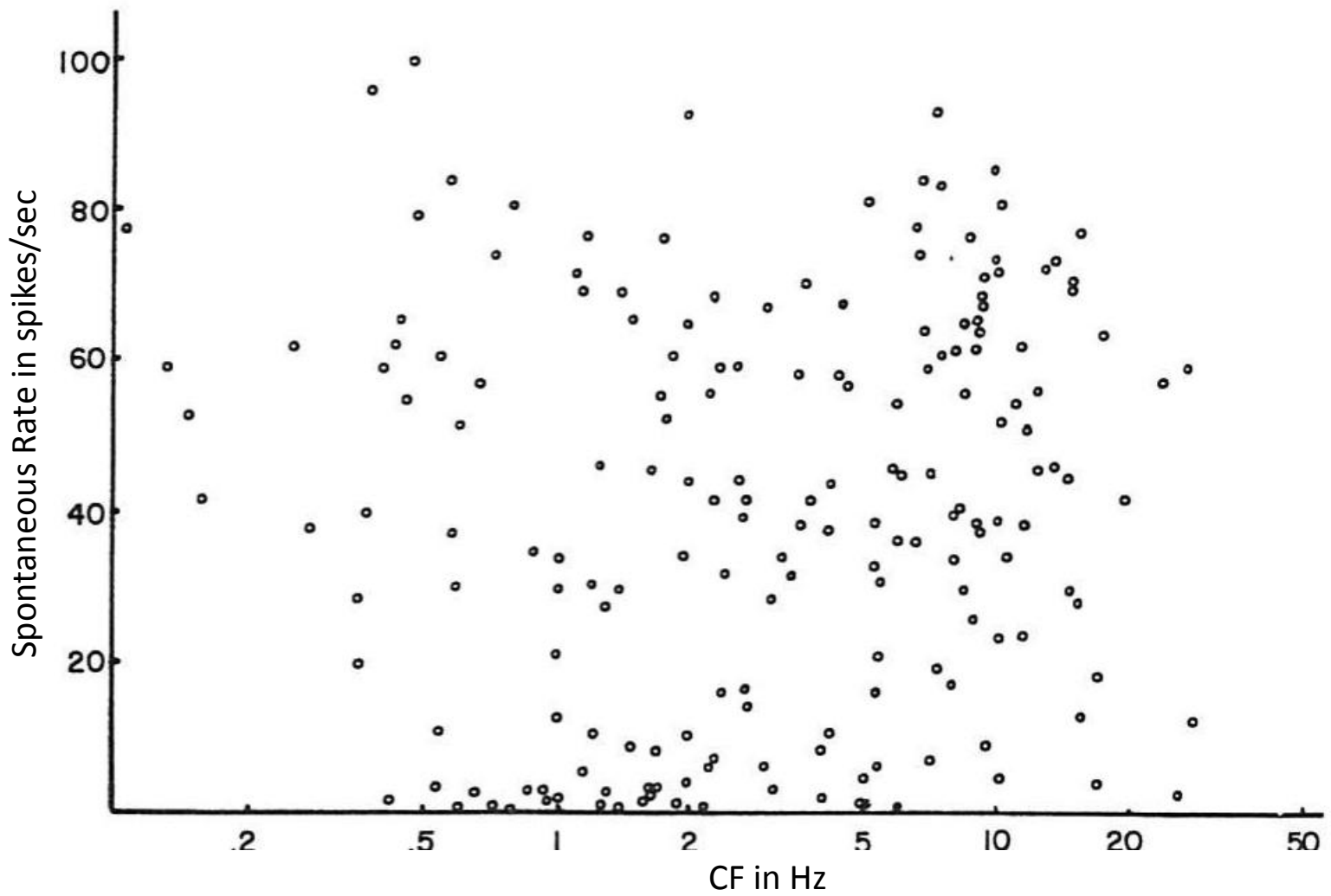

Data from 29 cats (Kiang, 1965)

DISCHARGE PATTERNS OF
SINGLE FIBERS IN
THE CAT'S AUDITORY NERVE

NELSON YUAN-SHENG KIANG

with the assistance of

Takeshi Watanabe, Eleanor C. Thomas, and Louise F. Clark

1965



RESEARCH MONOGRAPH NO. 35

THE M.I.T. PRESS, CAMBRIDGE, MASSACHUSETTS

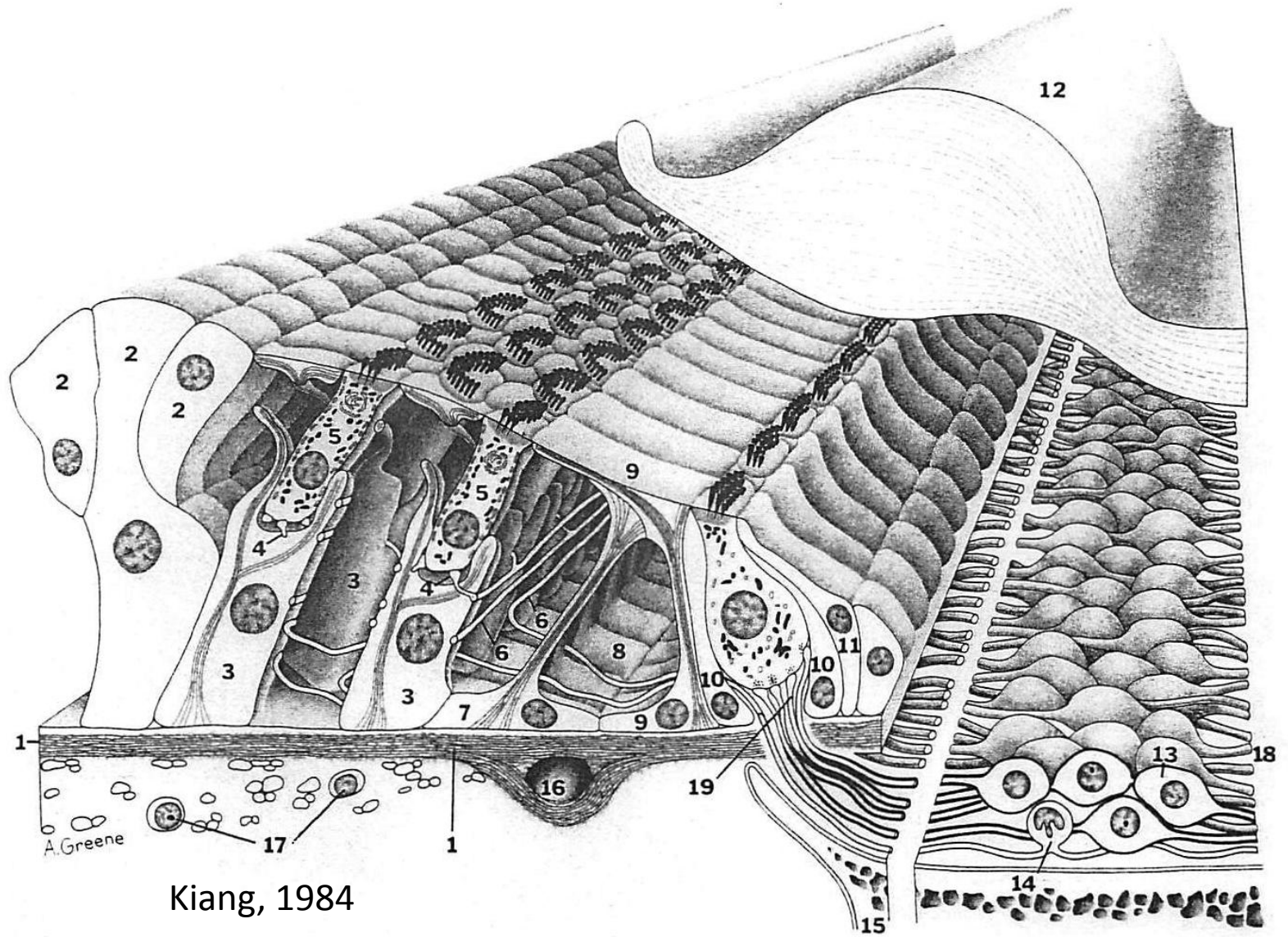

Auditory-nerve response from cats raised in a low-noise chamber

M. Charles Liberman

Eaton-Peabody Laboratory of Auditory Physiology, Massachusetts Eye and Ear Infirmary, Boston, Massachusetts 02114

(Received 27 June 1977; revised 16 September 1977)

A litter of four cats, born and raised in a soundproofed chamber, was studied in an attempt to determine which, if any, features of the auditory-nerve response from routinely available cats might be due to the chronic effects of noise exposure. Two features of routine-normal response were especially suspect in this regard: (1) a "notch" in the distribution of single-unit thresholds centered at characteristic frequencies (CF's) near 3 kHz and (2) a compression of the distribution of rates of spontaneous discharge for units with CF above 10 kHz. A third feature of response in routine animals was the presence of a small number (roughly 10%) of units with virtually no spontaneous discharge and very high thresholds, sometimes 80 dB less sensitive than high-spontaneous units of similar CF. In the data from chamber-raised animals, the high-spontaneous units showed exceptionally low thresholds at all CF regions, however, there were signs of the midfrequency notch in the threshold distribution of at least two of these animals. The compression of the spontaneous rate distribution was not seen in any of the three most sensitive animals. The data suggest that there is a significant amount of "normal pathology" in the high-CF units from routine animals. Low-spontaneous, high-threshold units were present in all four chamber-raised ears with the same characteristics as in routine animals (exceptionally narrow tuning curves and exceptionally low maximum discharge rates) and at roughly the same percentage of the unit sample. A class of units with medium spontaneous rates and intermediate thresholds could also be identified. The possible significance of a classification of auditory-nerve units according to spontaneous rate is discussed.

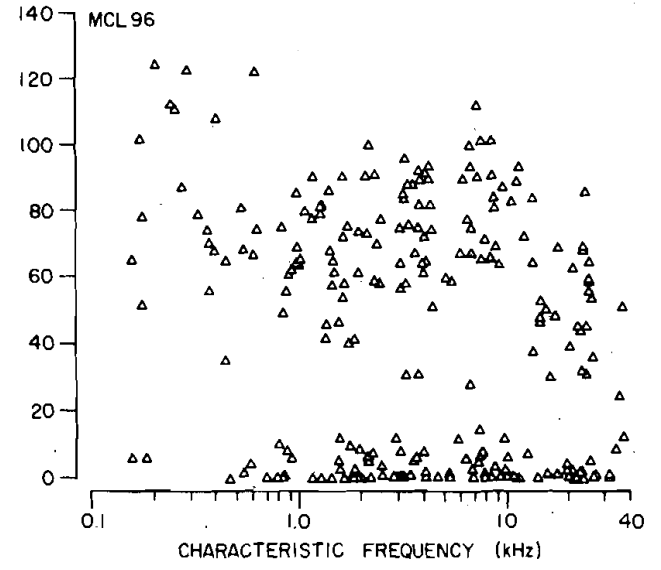
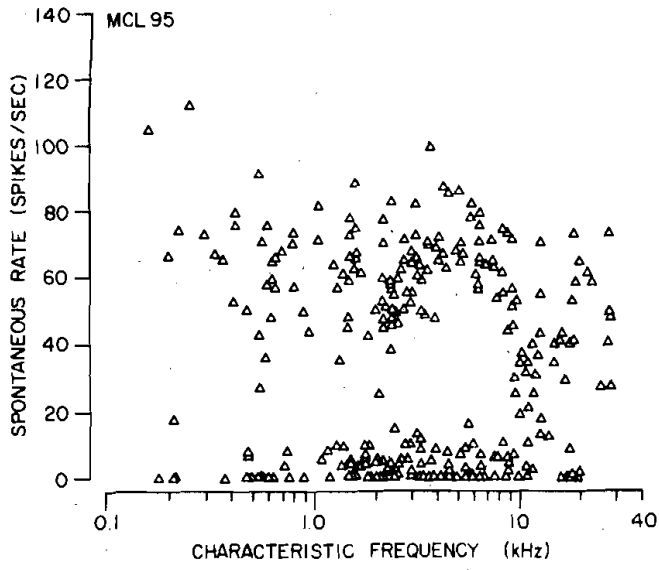
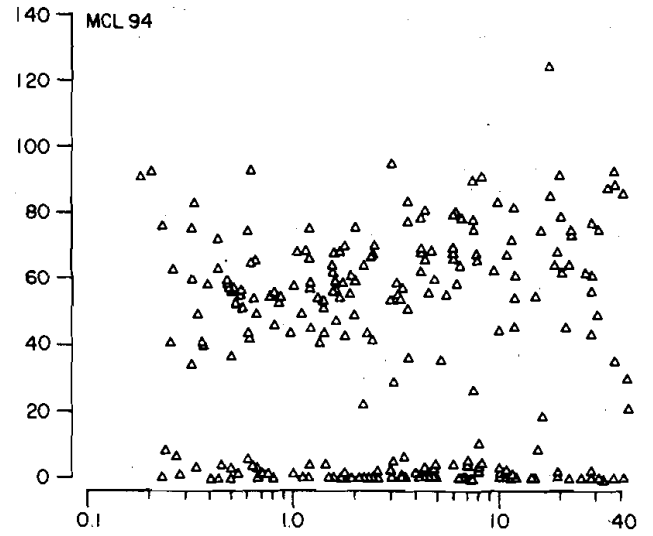
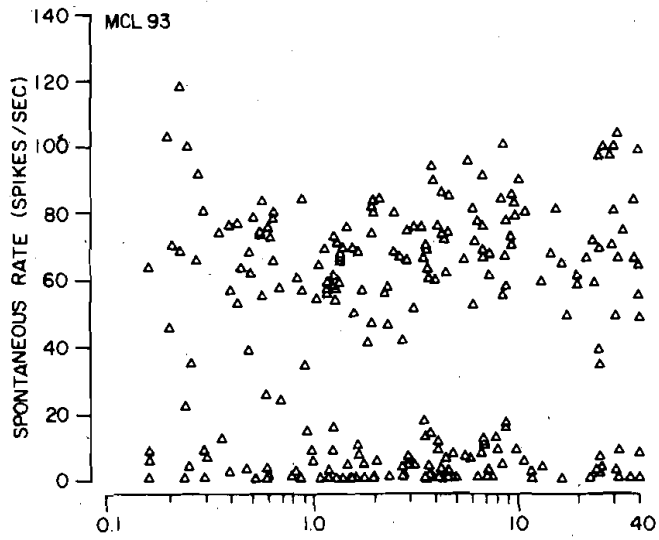

Data from 4 chamber-raised cats (Liberman, 1977)

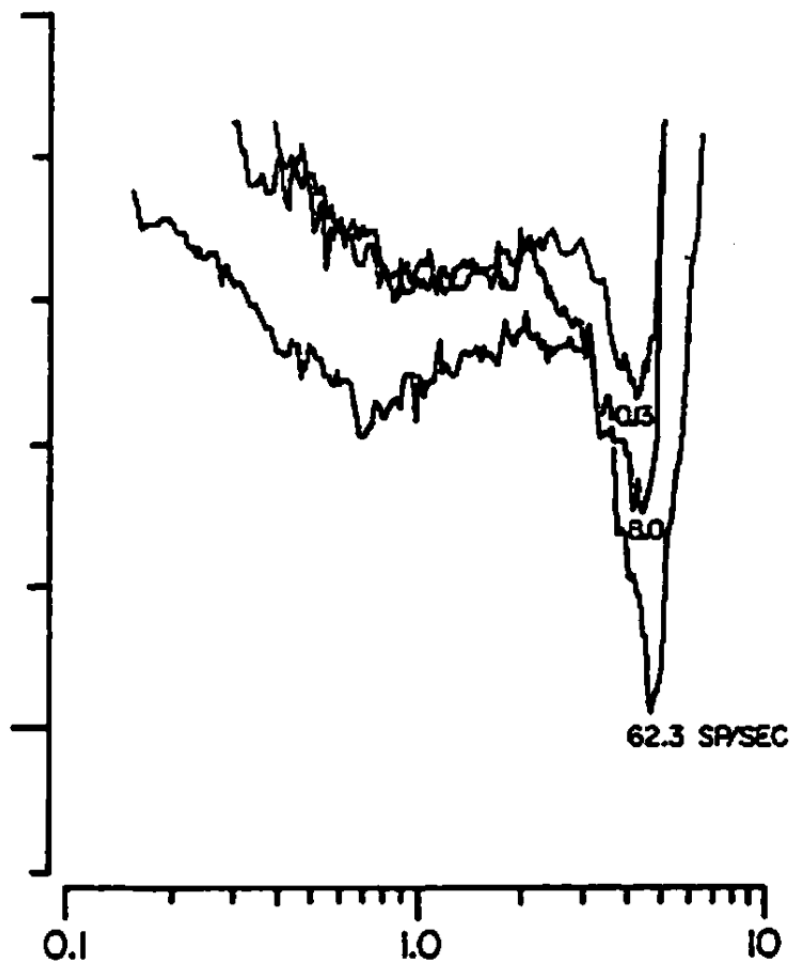
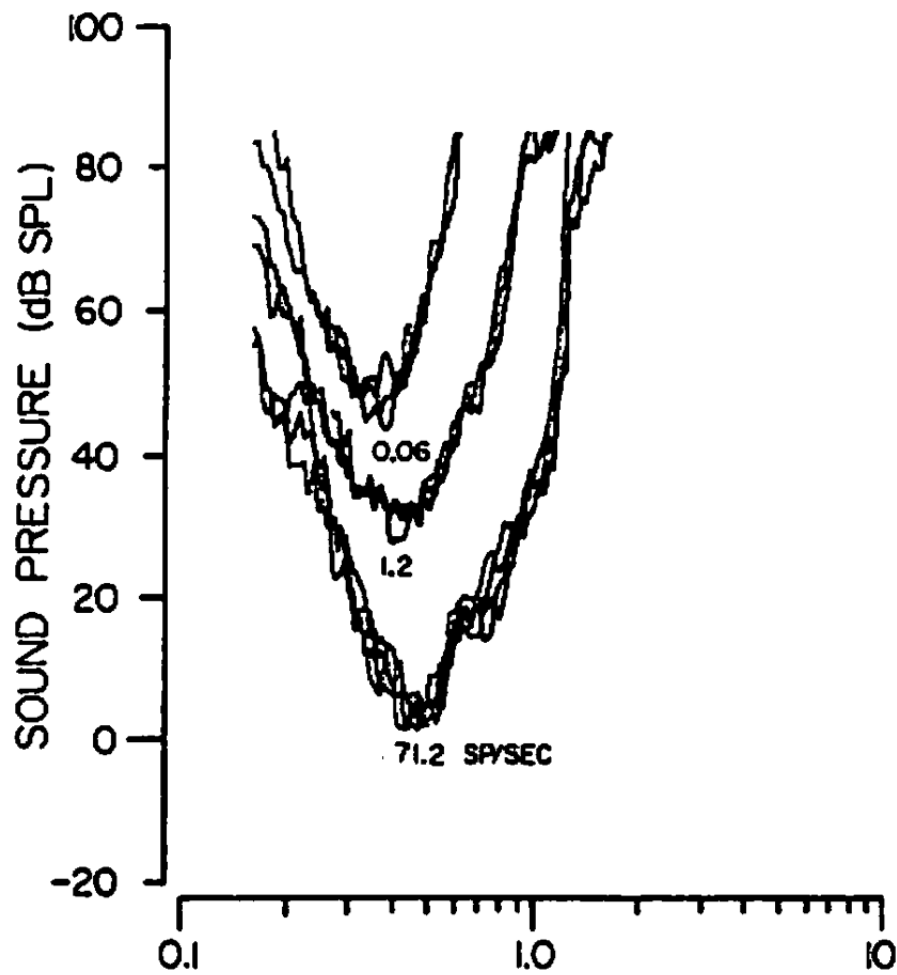

FREQUENCY (kHz)

Kiang, Keithley & Liberman, 1983

Acta
OTO-LARYNGOLOGICA

SUPPLEMENT 358

Acoustic Trauma in Cats

Cochlear Pathology and Audiotory-nerve Activity

BY

M. CHARLES LIBERMAN and NELSON Y. S. KIANG

1978

DISTRIBUTED BY

THE ALMQVIST & WIKSELL PERIODICAL COMPANY

STOCKHOLM, SWEDEN

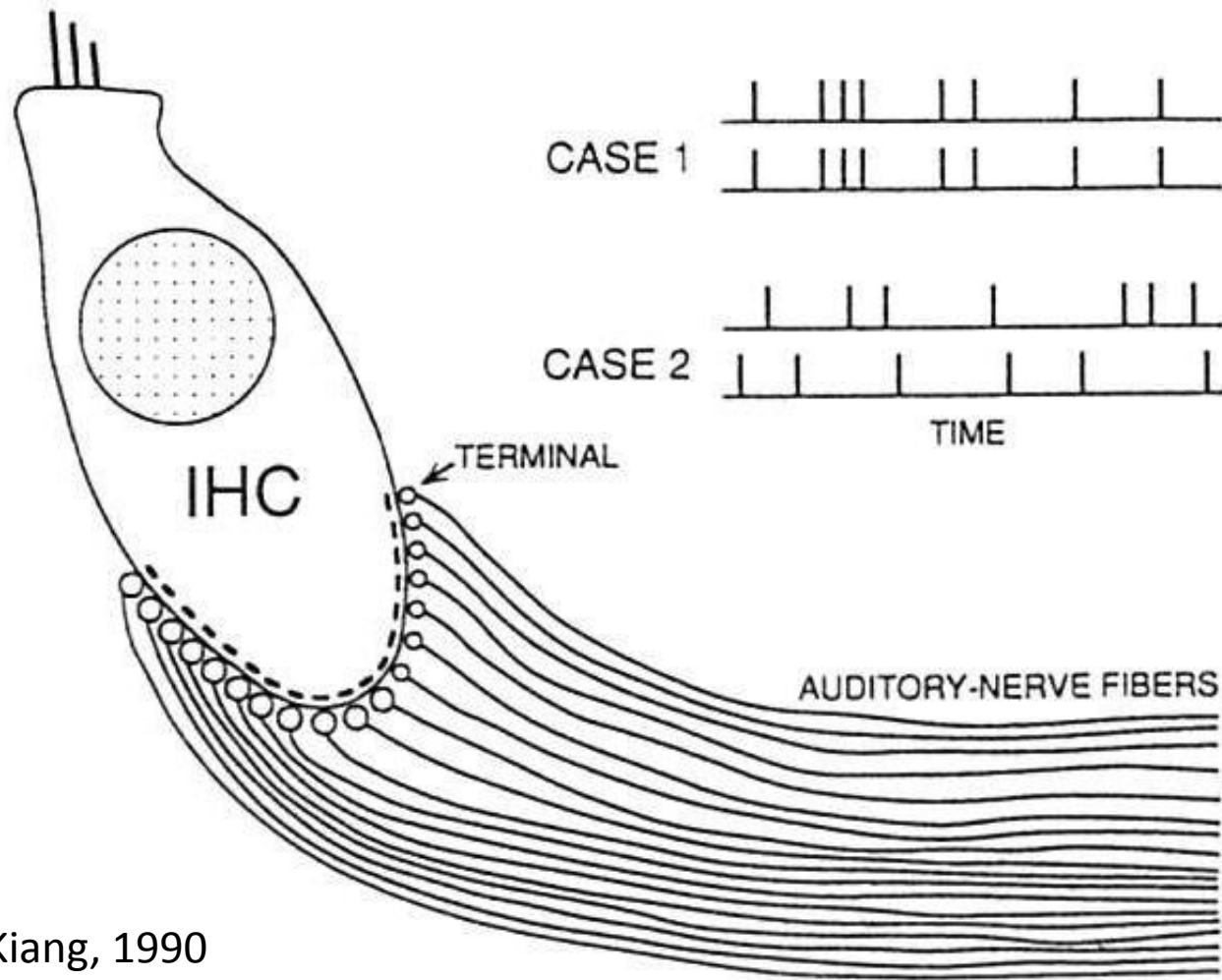

Kiang, 1990

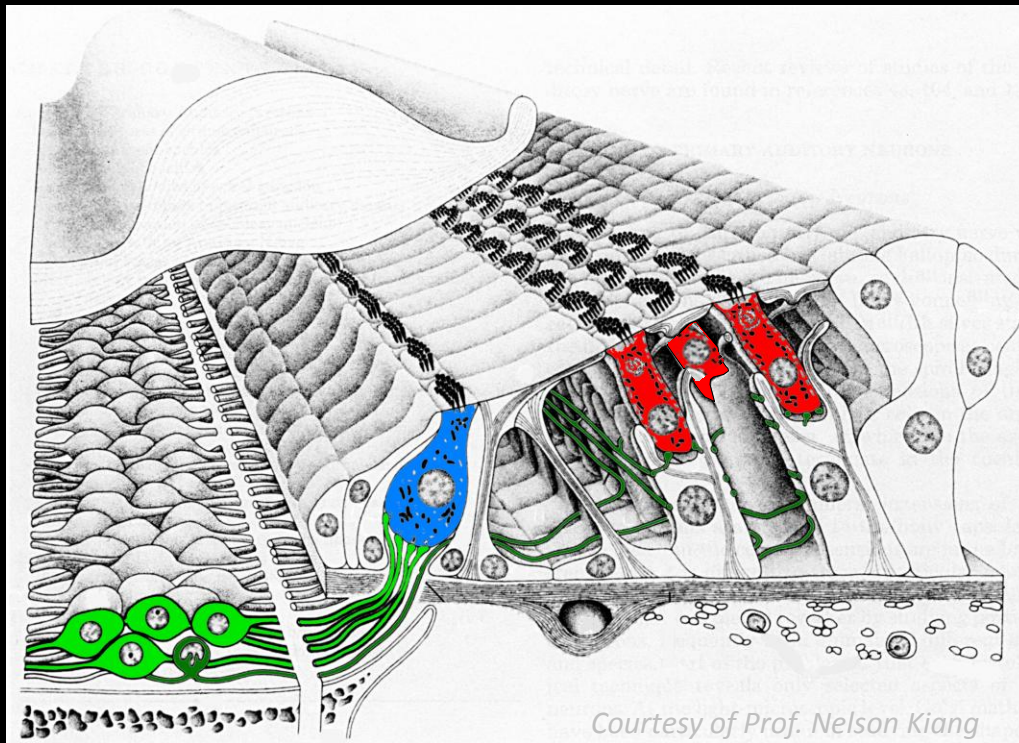

Outer hair cells - cellular motors that amplify motions

Inner hair cells - transduce information into electrochemical signals

Cochlear nerve fibers - carry the signals from inner hair cells to the brain

System is optimized to amplify low-level signals

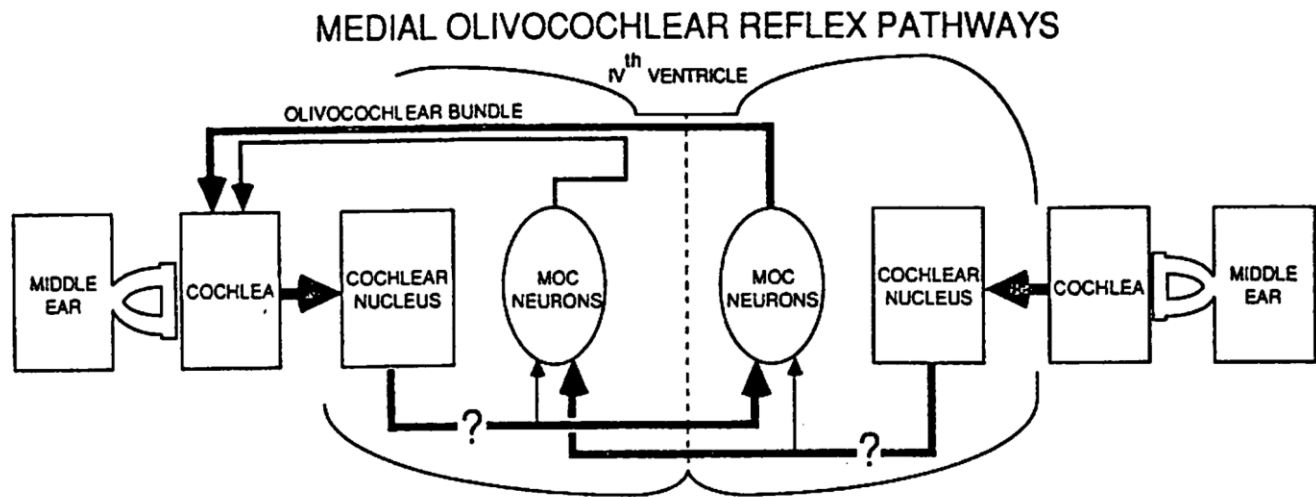
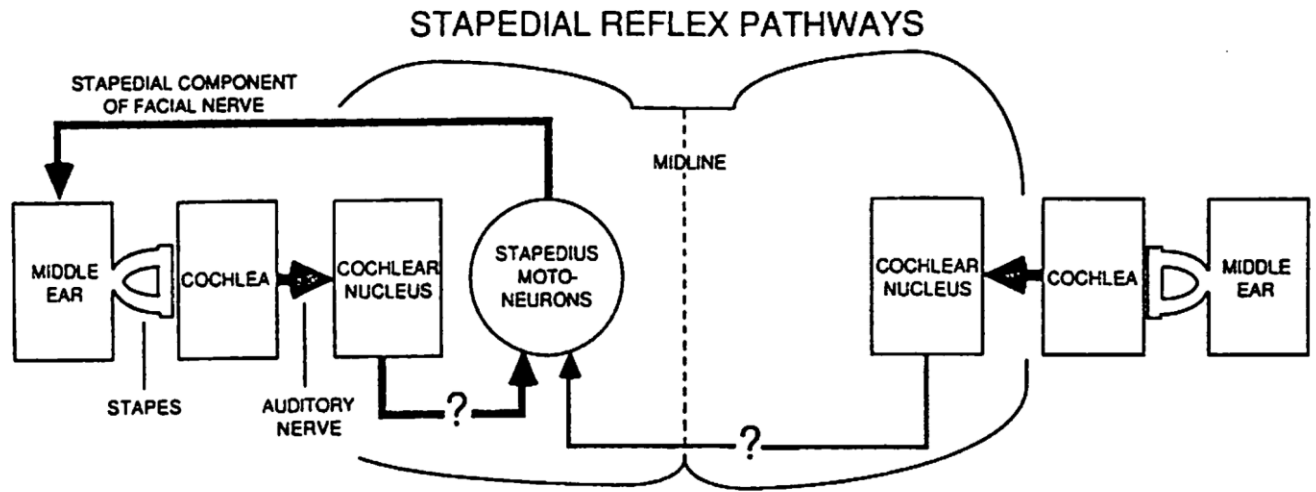

Two Reflex Pathways (Kiang, Guinan, Liberman, Brown & Eddington, 1987)

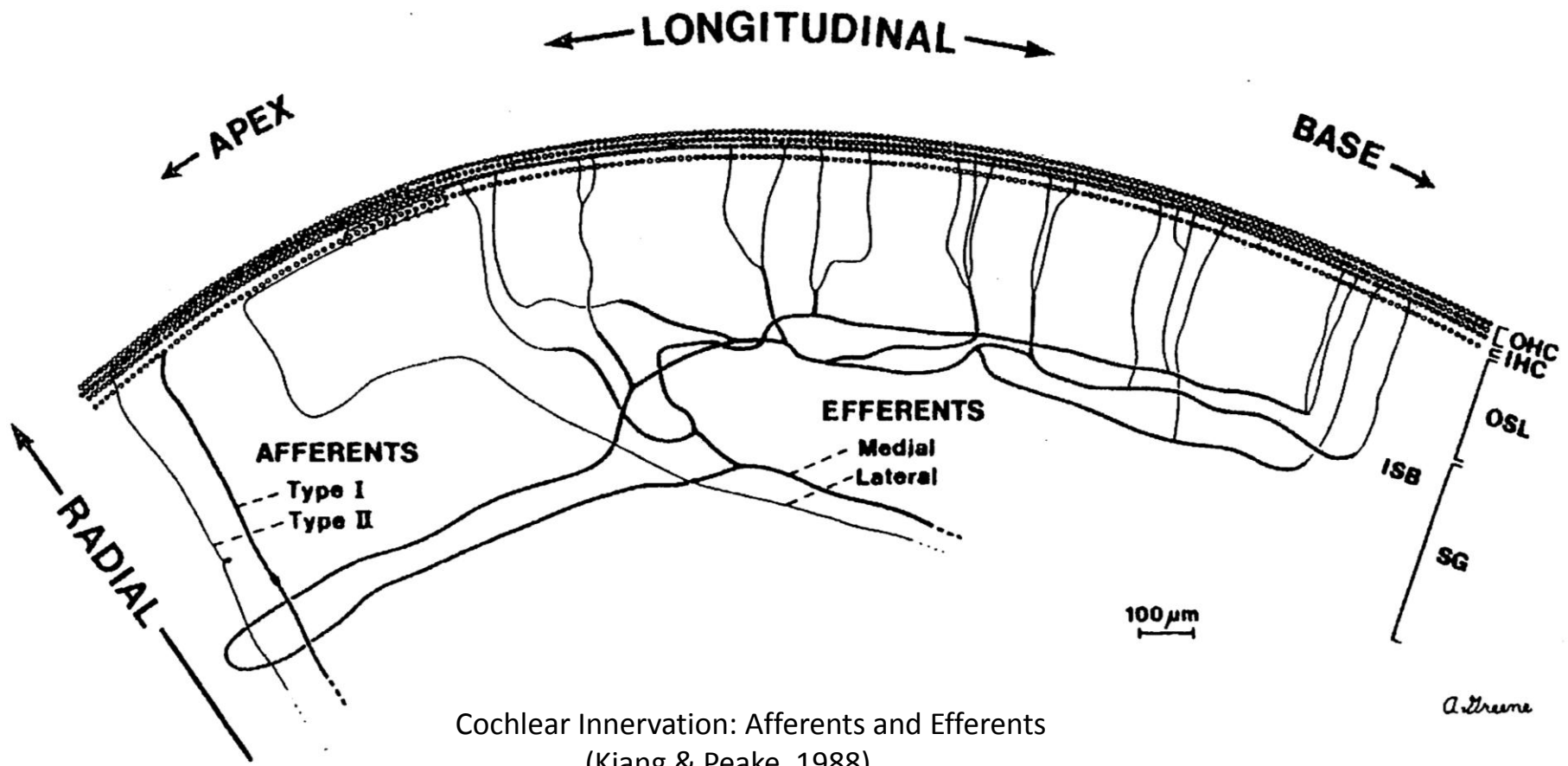

Cochlear Innervation: Afferents and Efferents
 (Kiang & Peake, 1988)

Slides presented for Istvan Ver by Mike Roark of Burns
& McDonald.





“Model-Scale Experimental Comparison Study of the Exhaust Configuration of the T-10 Jet Engine Test Cell Utilizing Lined Augmenters of Round and Square Cross Section” (I. Ver)



*“Dr. Ver is truly a trusted adviser. His knowledge and experience are unparalleled in the industry. When there are acoustic issues that require unique solutions – Dr. Ver is the guy you want on your team. Sometimes he doesn’t tell you what you want to hear, but he always tells you what you need to know. His recommendations are always spot-on and his contributions to our BMcD test cell projects have been crucial. There is nobody in the industry that I have more confidence in than **Dr. Ver.**”*

Leonard J. Danaher, Jr., PE*, FPE*, LEED® AP \ Burns & McDonnell
Senior Associate Mechanical Engineer \ Aviation & Federal



**PERFORMANCE EVALUATION
(CONSTRUCTION)**

1. CONTRACT NUMBER

2. CEC NUMBER

IMPORTANT: Be sure to complete Part III - Evaluation of Performance Elements on reverse.

PART I - GENERAL CONTRACT DATA

3. TYPE OF EVALUATION (X one)

INTERIM (List percentage _____ %)

FINAL

4. TERMINATED FOR DEFAULT

AMENDED

5. CONTRACTOR (Name, Address, and ZIP Code)
 BURNS & MCDONNELL ENGINEERING COMPANY, I
 9400 WARD PKWY
 KANSAS CITY
 MO 641143319
 USA
 NAICS Code: 236220

6.a. PROCUREMENT METHOD (X one)

SEALED BID

NEGOTIATED (Design-Build)

b. TYPE OF CONTRACT (X one)

FIRM FIXED PRICE

COST REIMBURSEMENT

OTHER (Specify)

7. DESCRIPTION AND LOCATION OF WORK

DESIGN AND CONSTRUCT JET ENGINE TEST CELL AT NAS MERIDIAN, MS AND AT NAS KINGSVILLE, TX.

EVALUATOR REMARKS: Burns & McDonnell has done an outstanding job on this contract from initial negotiations to completion of the building. This contract involved the design/build of two jet engine test cells, one in Meridian MS and one in Kingsville, TX. The design team from Burns & McDonnell brought excellent design experience in this field and suggested some changes to deliver the project within available funding. The project was designed to incorporate some features that are used in the commercial world without sacrificing quality. LANT has now adopted this type design as the prototype for future jet engine test cells. The cooperation and professionalism of Burns and McDonnell has also been outstanding. When the cell had to be modified to adapt the cell to the smaller airflow of the T45 engine, Burns & McDonnell worked with design engineers from LANT and NAVAIR to develop a fix. Throughout construction, the on site teams were vigilant to ensure quality construction and to quickly correct any deficiencies. Outstanding teamwork throughout the project was a guiding principal. A high quality facility was delivered to the Navy on time, safely and within budget that has become a standard for future facilities of this type. This project was also nominated by LANT for an award to the Design-Build Institute of America.

ensure quality construction and to quickly correct any deficiencies. Outstanding teamwork throughout the project was a guiding principal. A high quality facility was delivered to the Navy on time, safely and within budget that has become a standard for future facilities of this type. This project was also nominated by LANT for an award to the Design-Build Institute of America.



Navy Aircraft Acoustical Enclosures



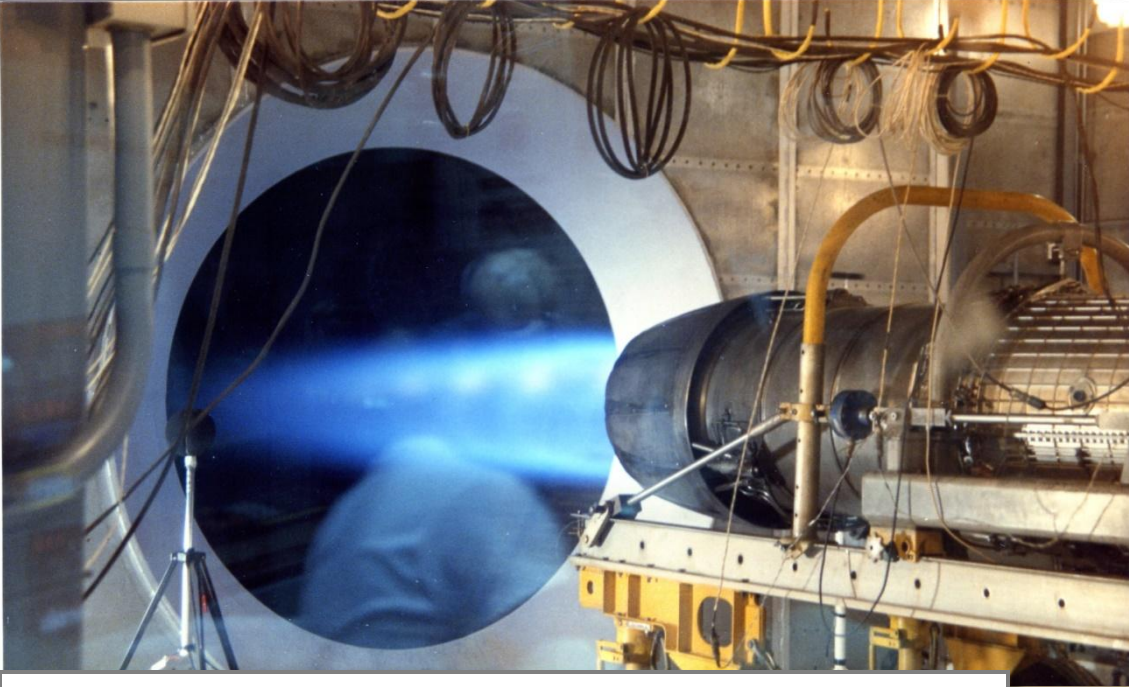

A word of gratitude for Istvan's many years of dedicated service to the Navy's jet engine test cell program:



“Istvan was an integral part of the initial design consultants team. He was responsible for developing the Navy's standard design for over 35 years of reliable service. He contributed his acoustical expertise resulting in the Department of Defense benchmark standard for jet engine testing in an enclosed facility. He was referred to as the man with the 4' wide brain who could simplify his solutions to allow practicing engineers to implement acoustical protection into the building design. His contributions resulted in a much safer working environment.”

Vincent Donnally | Special Assistant to the NAVFAC
Chief Engineer on Aviation Facility matters | Retired



Client wrote, "I would defer to Dr. Ver on the subject of acoustical dampening materials, Istvan Ver wrote my reference books on those subjects"

Anthony R. Pilon, Ph.D.
LM Fellow – Advanced Development Programs
Lockheed Martin Aeronautics Co.

Full Capability Run Stations

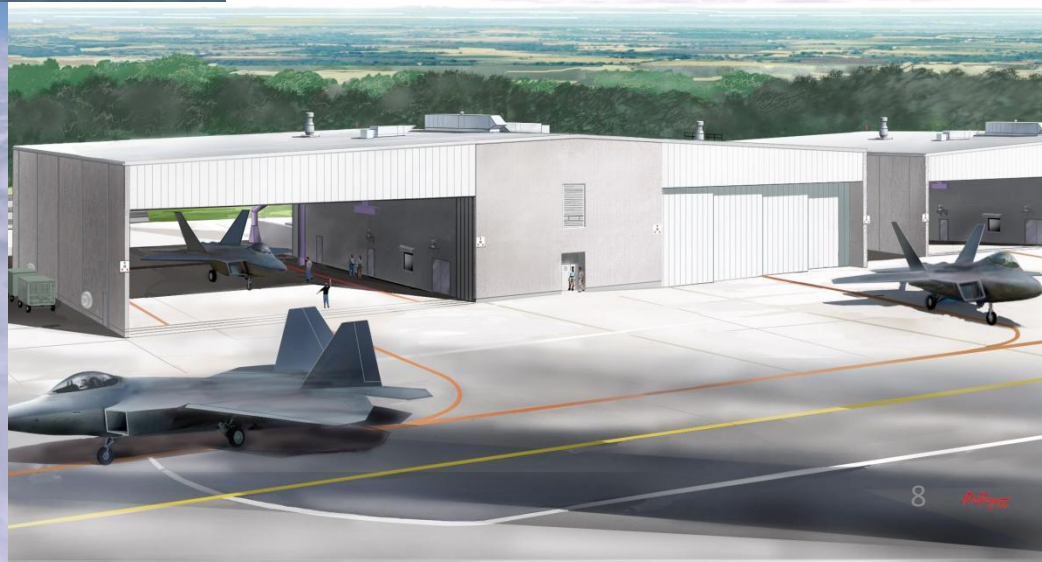
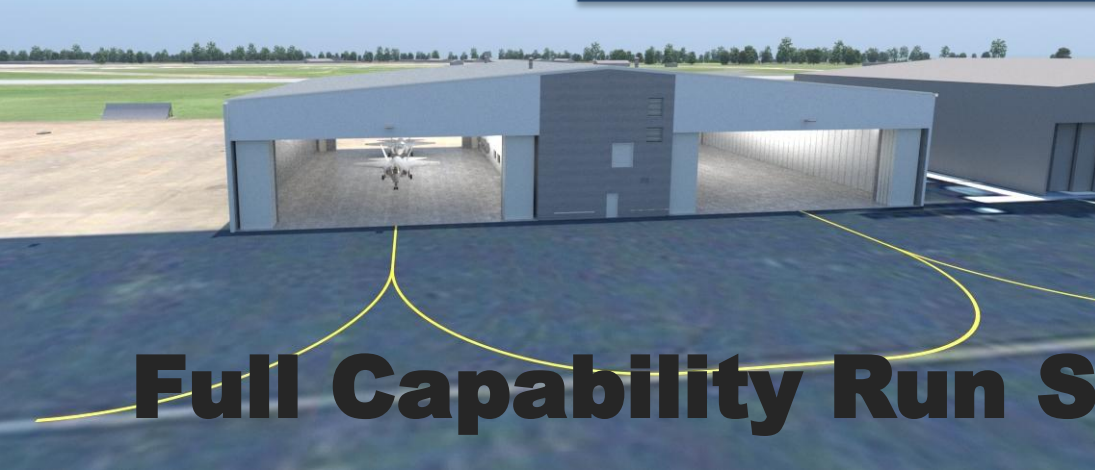

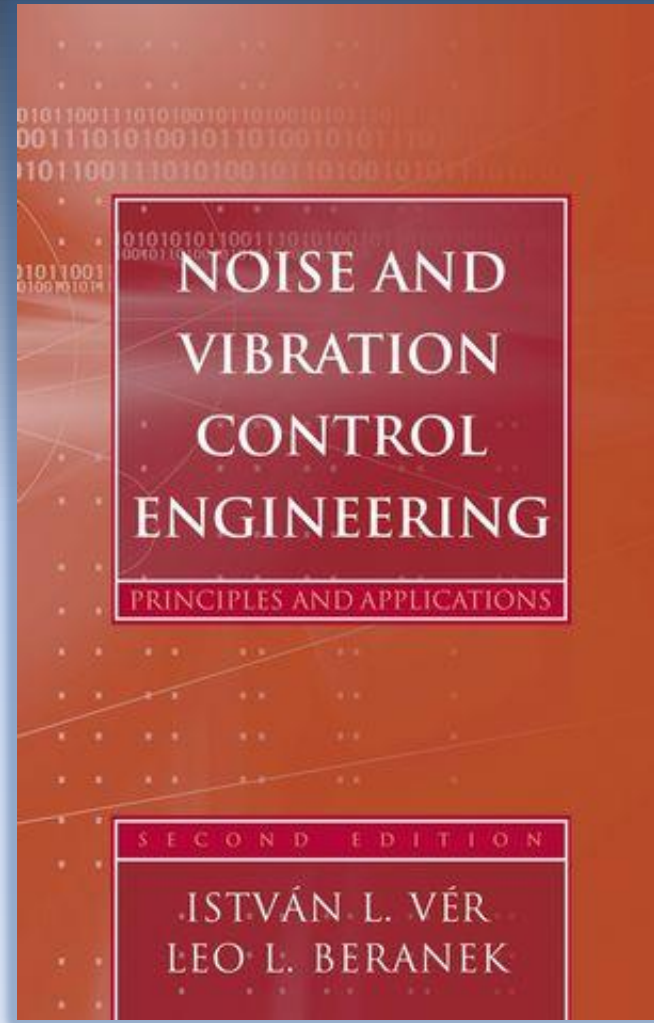

NOISE AND
VIBRATION
CONTROL
ENGINEERING

PRINCIPLES AND APPLICATIONS

SECOND EDITION

ISTVÁN L. VÉR
LEO L. BERANEK

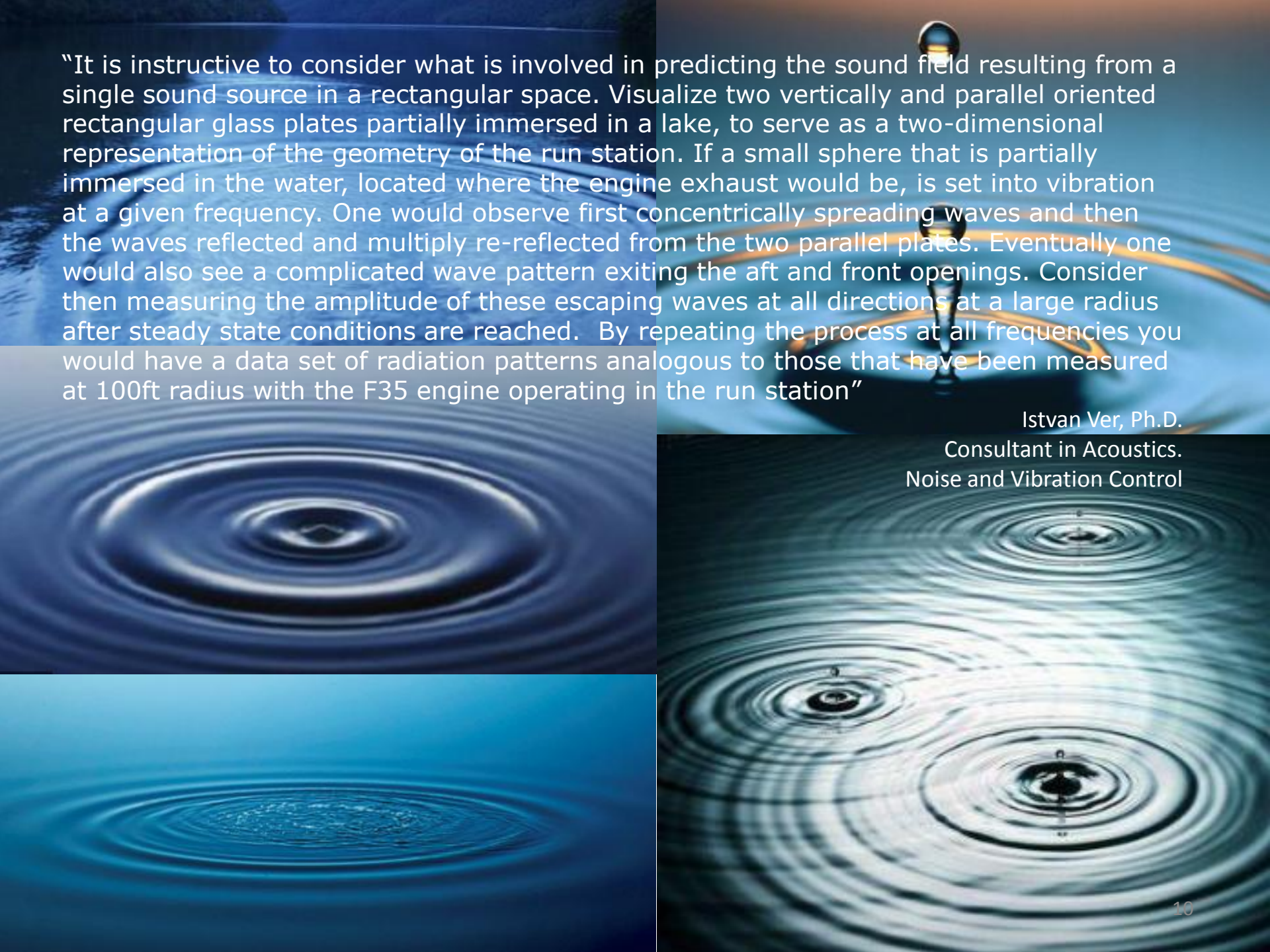
The background of the slide is a composite image. The top half shows a close-up of a small, dark, reflective sphere (like a ballpoint pen tip) just touching the surface of blue water, creating a small splash and concentric ripples. The bottom half of the slide is dominated by a large, detailed image of water ripples, showing multiple concentric circles of varying sizes and colors (from light blue to dark blue) spreading out from a central point. The text is overlaid on the top half of this image.

“It is instructive to consider what is involved in predicting the sound field resulting from a single sound source in a rectangular space. Visualize two vertically and parallel oriented rectangular glass plates partially immersed in a lake, to serve as a two-dimensional representation of the geometry of the run station. If a small sphere that is partially immersed in the water, located where the engine exhaust would be, is set into vibration at a given frequency. One would observe first concentrically spreading waves and then the waves reflected and multiply re-reflected from the two parallel plates. Eventually one would also see a complicated wave pattern exiting the aft and front openings. Consider then measuring the amplitude of these escaping waves at all directions at a large radius after steady state conditions are reached. By repeating the process at all frequencies you would have a data set of radiation patterns analogous to those that have been measured at 100ft radius with the F35 engine operating in the run station”

Istvan Ver, Ph.D.
Consultant in Acoustics.
Noise and Vibration Control



JAPAN AIRLINES



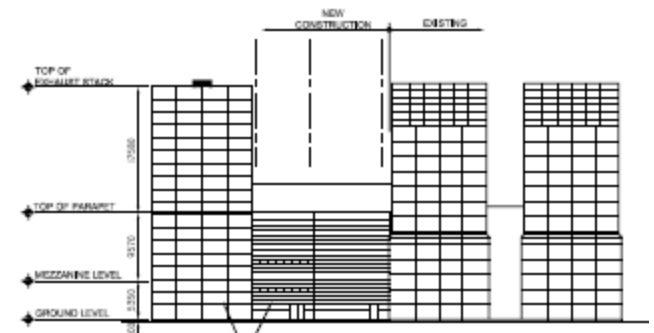
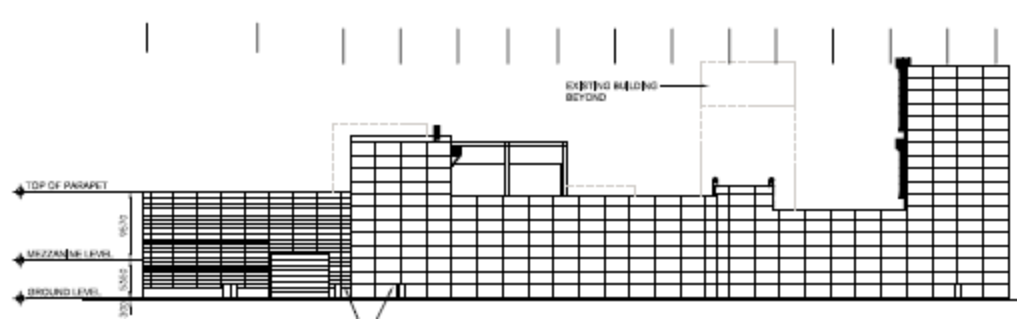
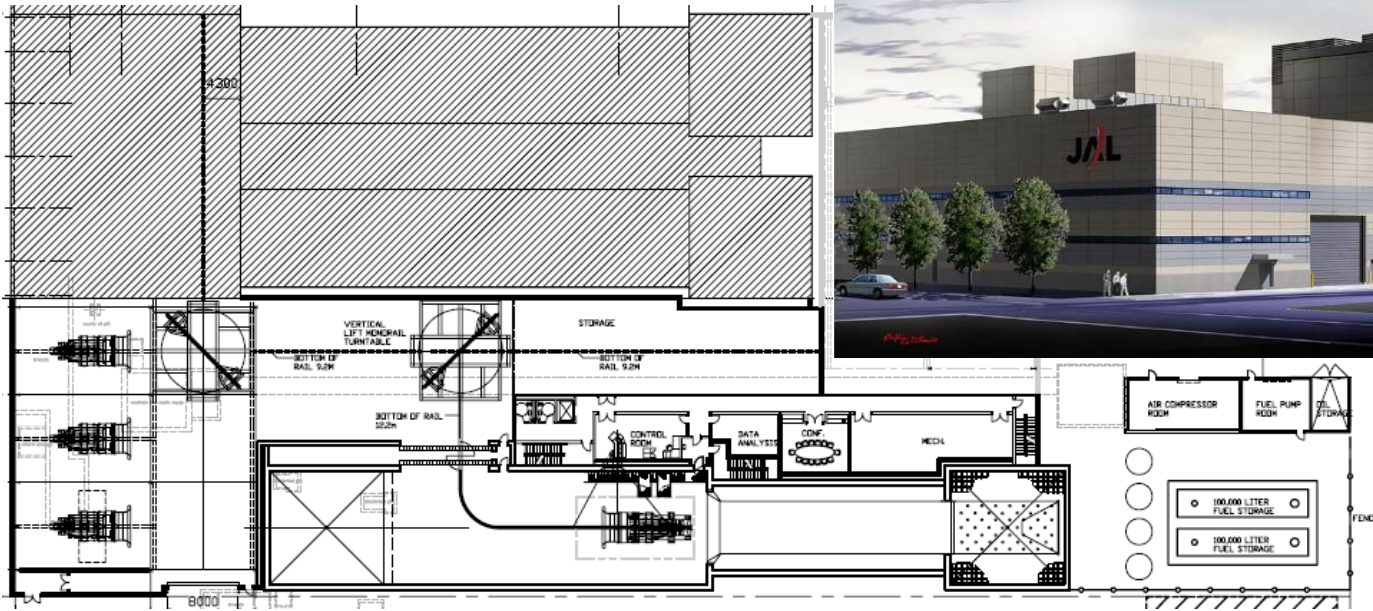



GE Jet Engine Test Facility Tests Production Engines GE90, GEnx , GE9X & LEAP Engines



We Invent the Future of Flight, Lift People Up
and Bring Them Home Safely.





“Preliminary Acoustic Design Report of the General Electric Peebles Test Cell 5C for the GE90-115 and GE CF6-80C2 Engines” (I. Ver)
Report submitted to Burns & McDonnell Engineering Company, 16 March 2006

“Diagnostic Study of the Apparent Low Frequency Trust Fluctuations in the General Electric Company's 5D Test Cell in Peebles.”
Letter Reports submitted to Burns & McDonnell Inc., 2013

Making Our Clients Successful

Our mission and our focus, every day, on every project.

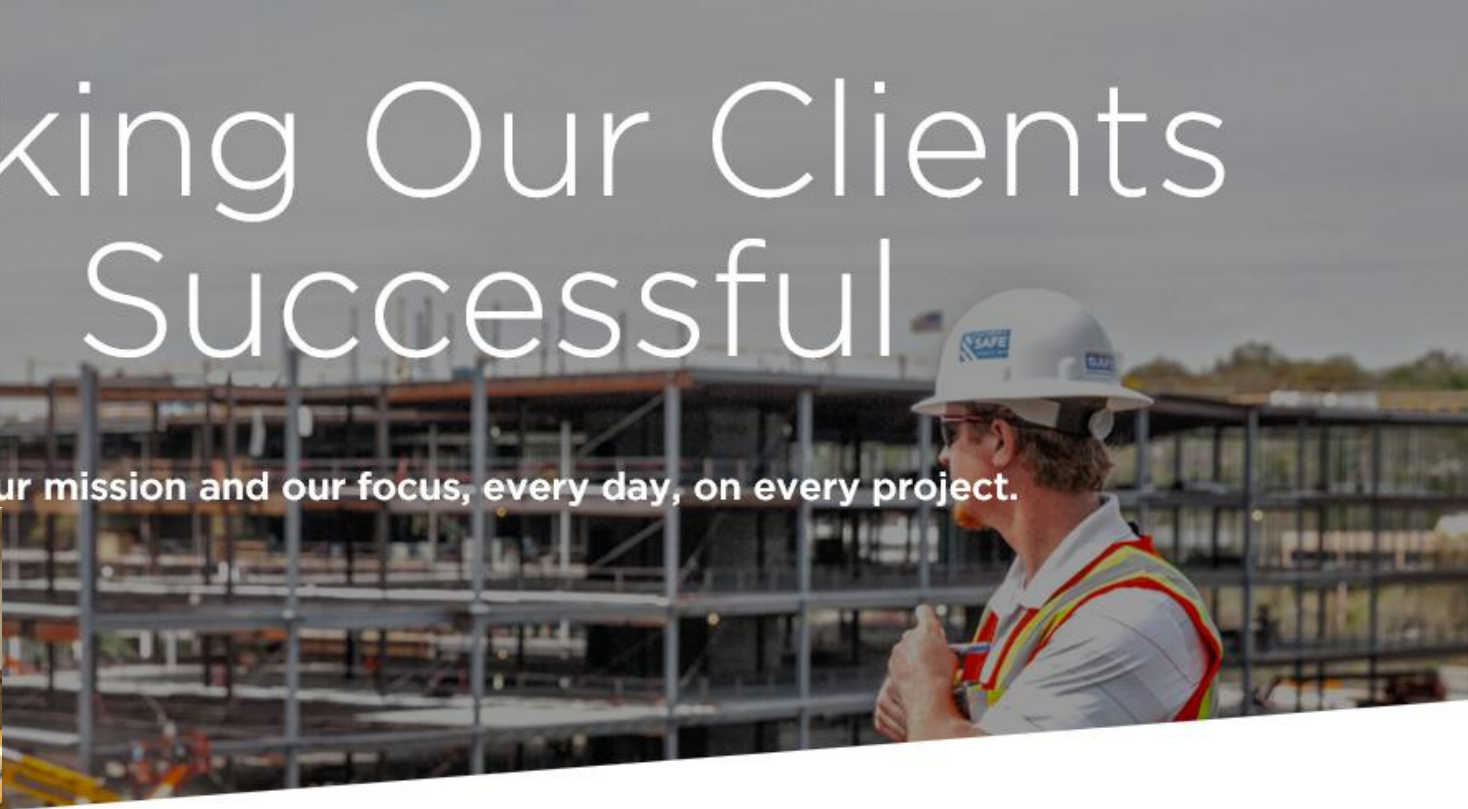

Thank You Dr. Ver

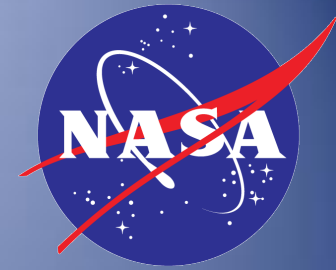

István Vér

Contributions to NASA

Kevin Shepherd
NASA Langley Research Center
Hampton, VA

NoiseCon 2016
June 13-15
Providence, RI

First Visit to NASA Langley

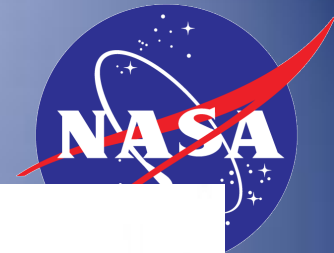

Left to right: Messrs. Istvan L. Ver (Displaced Person), Senior Scientist, Bolt, Beranek and Newman, Cambridge, Massachusetts and Jimmy M. Cawthorn, Langley Research Center.

October 7, 1970

István's Contributions to NASA

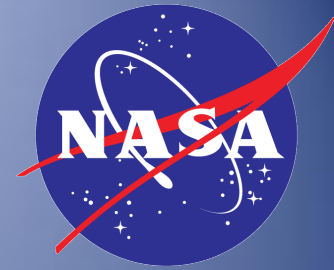

- Facility design
- Research activities
- Personal Recollections

Wind Tunnels



Langley Full Scale Tunnel (30x60)

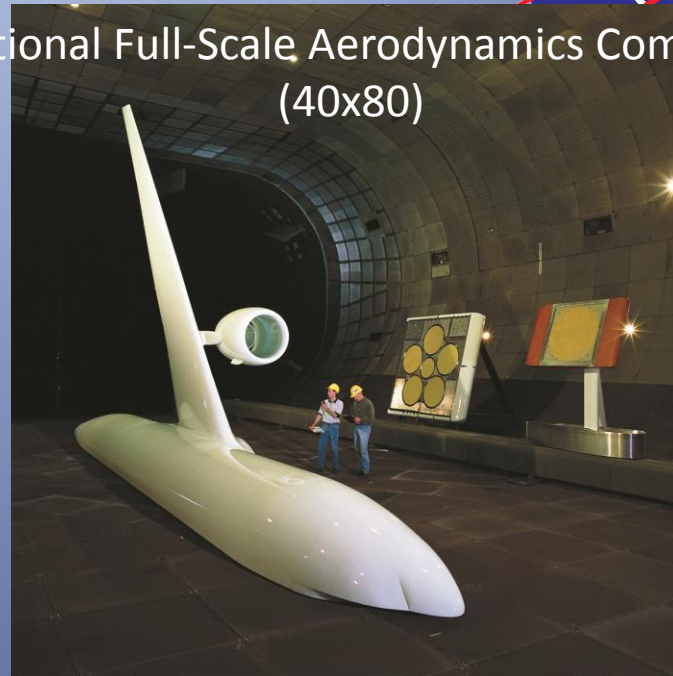

National Full-Scale Aerodynamics Complex (40x80)



V/STOL (14x22)



National Transonic Facility

NASA Langley Acoustics Research Laboratory

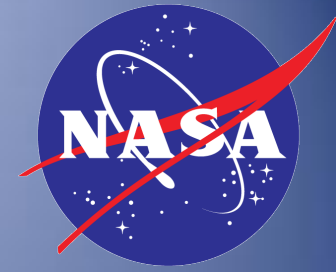

Exterior Effects Room

Quiet Flow Facility



Other Research Activities

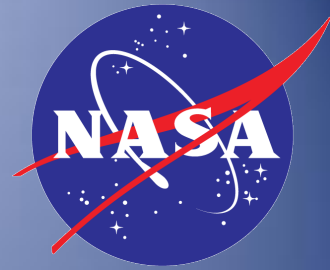

- Vacuum bubbles
- Hardware in anechoic chambers
- Sonic boom simulator
- Acoustic reciprocity

Sonic Boom Simulator (Canoga Park)

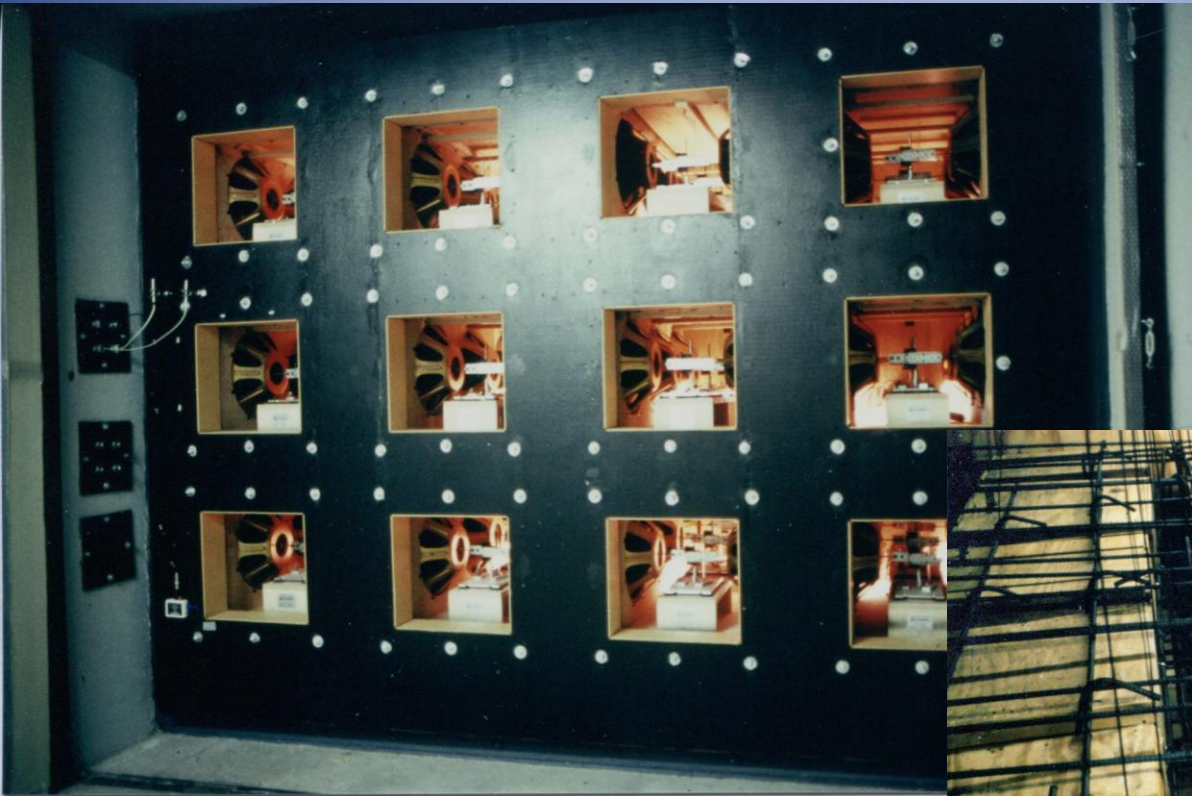
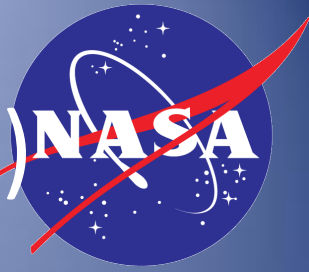

Acoustic Reciprocity

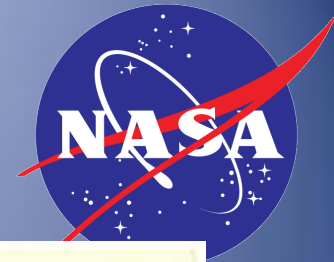

NASA
L-81-7823





Dodecahedra Sources

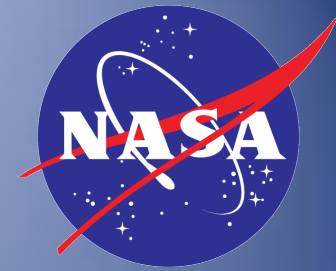

Calibrated Reciprocal Transducer (source and receiver)

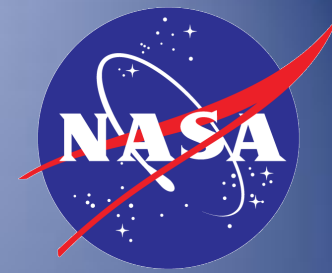

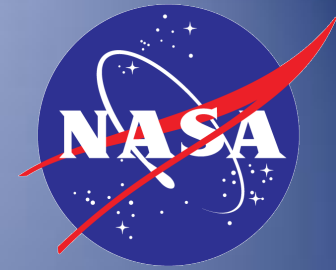

Recollections

- I knew of István before I knew him

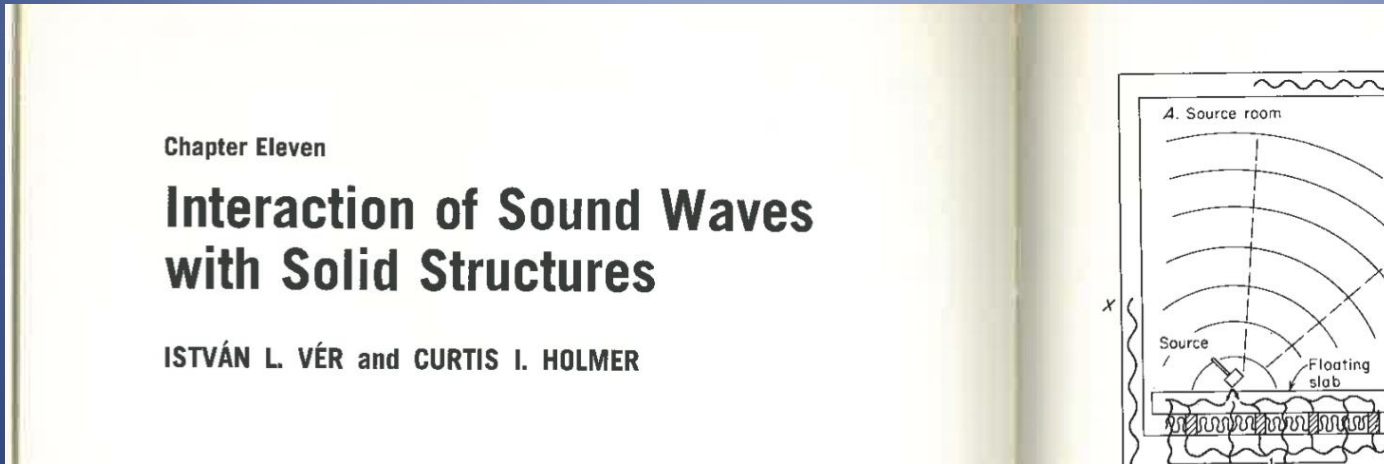

- What I have learned since:
 - He is creative
 - He is thorough
 - He loves teaching
 - He is a true gentleman



Slides presented for Istvan Ver by Jim Barnes principal
Consultant at Acentech in Cambridge.

**István Vér,
Scientist, Engineer,
Consultant & Teacher**

James D. Barnes

Early BBN Years

My first impressions

BBN

Engineering Information (EI) Sheets

EI SHEETS - NUMERICAL LISTING - CUMULATIVE
(SUPERCEDES EARLIER NUMERICAL LISTING)

1.0 MISCELLANEOUS

CHAPTER I - GENERAL TECHNICAL INFORMATION

1.01 EFFICIENT SIZE OF SOUND REFLECTORS

1.1 Wavelength in Air vs. Frequency

1.2 Conversion of SPL to Sound Pressure in Dynes/cm², lbs/ft², lbs/in²
(20 to 100dB)

1.3 As 1.2 but range is from 100 to 200 dB

1.4 Combining SPL's in dB's and Correction for Background Noise

1.5 Conversion of Reverberation Time to Decay Time

1.6 Computing Volume of Odd-Shaped Halls (2 sheets)

1.7 Average Excess Attenuation in Octave Band for Sound Propagation in
Tree Areas in dB per 100 Feet (BBN Report No. 844)

1.8 Cost/Space Requirements for Pipe Organs

1.9 Averaging Fluctuating Levels on a Graphic Level Recorder

1.10 Barrier Attenuation

1.11 Attenuation with Distance from Roadway

CHAPTER II - ROOM ACOUSTICS

2.1 Distance from Non-Directional Source where Direct and Reverberant
Sound are Equal

2.2 Approximate SPL Median between Floor and Ceiling in a "Two Dimensional"
Room as a Function of Distance from the (Point) Source (10ft. ceiling)

2.3 Same as 2.2 but 20 ft. ceiling

CHAPTER III - SOUND ABSORPTION

3.1 % Open Area of Perforated Materials

3.2 Absorption Coefficient of Grill Having Rectangular Elements

3.3 Sound Absorption Coefficient of Eggcrate Grating with Perfectly
Absorptive Backing

3.4 Reflection Absorption vs. TL Field Incidence

3.5 Reflected Pressure vs. Absorption Coefficient

3.6 Graphs for Determining Loudness Reduction

3.7 Limitation of Reverberation Time by Atmospheric Absorption

3.8 Statistical Absorption Coefficient

3.9 Range of Absorption Coefficients for Carpets

3.10 Carpet Absorption (Revision)

3.11 Effect of Impermeable Film on Absorption of Aerocar

3.12 Absorptive Characteristics of Spaced Treatments (Ref.: U. Ingard
and R. H. Bolt, "Absorption Characteristics of Acoustic Material
with Perforated Facings," JASA 23:533, 1951)

3.13 Same Title as 3.12

3.14 Same Title as 3.12

3.15 Same Title as 3.12

3.16 Energy Absorption Coefficient vs. Sabine Coefficient

3.17 Sabine Absorption Coefficients (11 sheets)

- General Technical Information
- Room Acoustics
- Sound Absorption
- Transmission Loss
- Structure-Borne Transmission Loss
- Noise Sources
- Future Material
- Standards, Criteria, and Codes
- Sound System Design
- Acoustical Measurements

Graphical Method for the Calculation of Improvement in Transmission Loss (Δ TL) Obtained by Adding a Thin "Skin" to a Heavy Partition.

Attached is a description of the calculation method and the graphs necessary for a quick evaluation of the improvement in transmission loss obtained by adding a thin "skin" to a heavy structural partition.

When using the method described, be aware of the limits set by unavoidable flanking paths (especially if looking for improvements above 20 dB). In order to be able to refine the method, please collect field data which we should evaluate at the TL seminar next year. (This sheet dated 13 December 1967/I. L. Ver)

SOUND ABSORPTION COEFFICIENT OF ACOUSTIC FOAMS

These EI-Sheets 1) list the major manufacturers of sound absorbing acoustical foams 2) provides a short description of the products and 3) gives the random incidence sound absorption coefficient for mounting No. 1 (i.e. the absorptive layer is backed by a hard surface) both in tabular and in graphical form. The data have been collected by Wayne Wallace.

Note that all data have been taken directly from the manufacturers catalog and have been obtained from impedance tube measurements (i.e. normal incidence case) by applying numerical corrections to obtain the listed "random incidence" or "statistical" absorption coefficient as suggested in EI 3.8. It should be remembered at this point that such a simple correction presumes a locally-reacting material (i.e. no sound propagation in the foam in the direction parallel to the hard wall) which is certainly not correct at low frequencies and for nearly grazing incidence; and one may anticipate some discrepancy between predicted and measured values at low frequencies. Accordingly, if you have absorption data of the listed materials obtained by the reverberation room method please send it to István L. Vér or T.J. Schultz to enable us to assess the effect of this correction method.

If you have data on other foam material not included in this list please send it to us.

István
István L. Vér
7/6/71

Led Technical Research

E I 4.5
11 August 1971
I.L.V.

OPERABLE WALL CATALOG

Tedd Boys has put together an excellent catalog on movable partitions. The catalog includes 50 different products of 10 manufacturers. The following information is provided:

- 1) Date Information Obtained
- 2) Manufacturer's Name, Address
- 3) Wall Type
- 4) STC
- 5) Test Laboratory & Test No.
- 6) Operation (i.e. manual or electric)
- 7) Weight per Unit Surface Area (lb/ft²)
- 8) Weight of Suspension (lb/ft)
- 9) Stack Space
- 10) Force Required to Open and Close Partition
- 11) Force Required to Operate Crank
- 12) Cost per square feet
- 13) Source & Date of Price Quotation
- 14) Maximum Available Size
- 15) Type of Floor, Head & Vertical Seal
- 16) Floor Track
- 17) Support
- 18) 1/3-oct. Band or Octave-Band TL data
- 19) N-Rating

Due to the high printing cost, no individual copies are distributed. However, each office will obtain a complete set from Tedd which will be deposited in the Master EI File available to everyone to use. I urge you to help Tedd Boys keep this catalog up to date and give to him, Ted Schultz or to me any information you may have on this subject.

István

Bolt Beranek and Newman Inc.
Report No. 2691

I.L. Ver
D.W. Andersen
M.M. Myles

A Design Guidebook
Prepared for the
Consolidated Edison Company
of New York Inc.
June 1976



Noise Control of Electrical Substations in High Rise Buildings

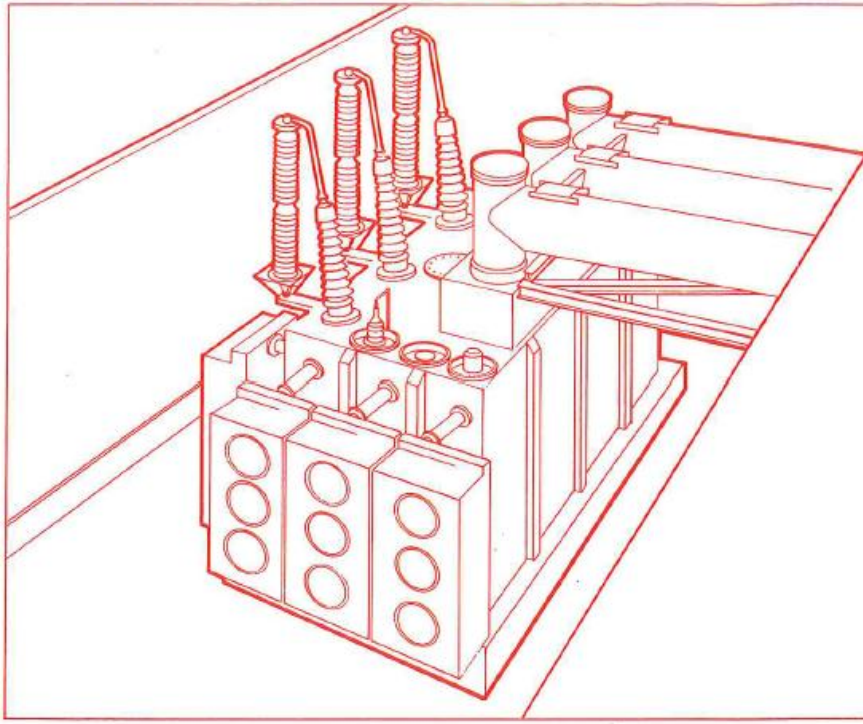

Premier
Acoustical
Consultant

Technical Research

Bolt Beranek and Newman Inc.
Report No. 3305

Prepared for
Empire State Electric Energy
Research Corporation

July, 1977

Characterization of Transformer Noise Emissions

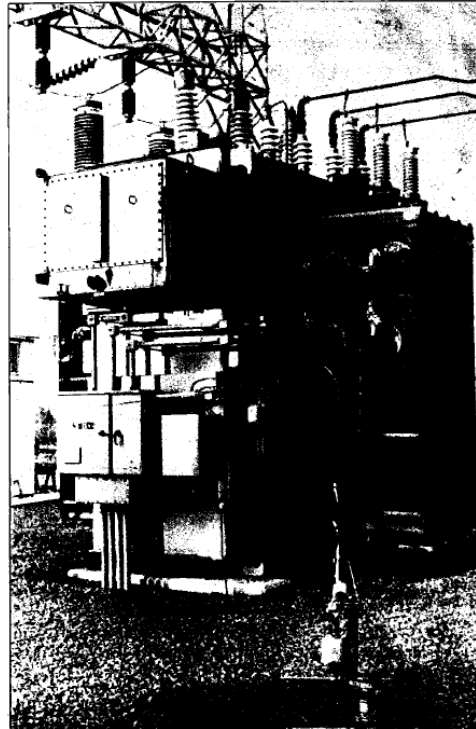

Volume **1**
Technical Report

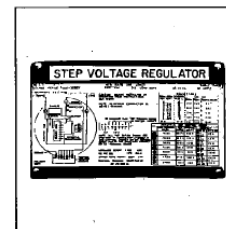
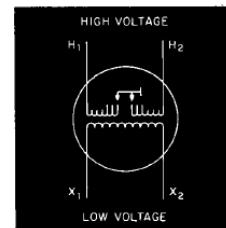

Guidebook

Bolt Beranek and Newman Inc.
Report No. 3305

Prepared for
Empire State Electric Energy
Research Corporation

July, 1977

Characterization of Transformer Noise Emissions

Volume
Technical Report

1

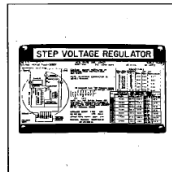
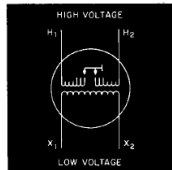
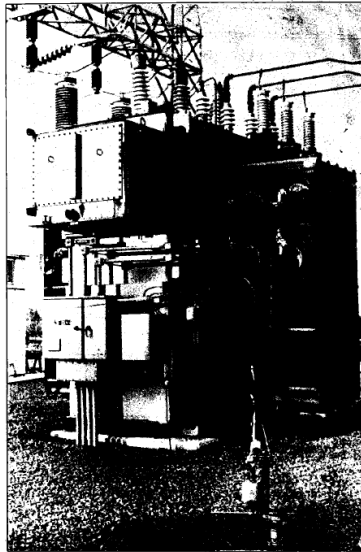

Bolt Beranek and Newman Inc.
Report No. 3305

Prepared for
Empire State Electric Energy
Research Corporation

July, 1977

Characterization of Transformer Noise Emissions

Volume
Substation Siting Guide

2

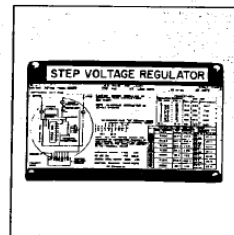
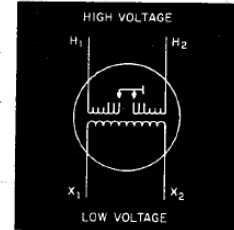
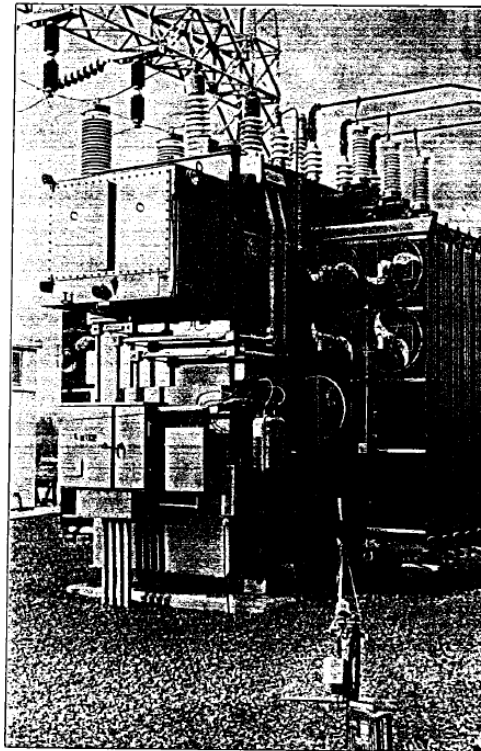

ASHRAE Studies

Bolt Beranek and Newman Inc.



Report No. 5116

Prediction of Sound Transmission Through Duct Walls; Breakout and Pickup

ASHRAE TRP-319

István L. Vér

January 1983

Prepared for:
American Society of Heating, Refrigeration,
and Air Conditioning Engineers, Inc.

2011 ASHRAE® HANDBOOK

Heating, Ventilating, and Air-Conditioning APPLICATIONS

Inch-Pound Edition

American Society of Heating, Refrigerating and Air-Conditioning Engineers, Inc.

1791 Tullie Circle, N.E., Atlanta, GA 30329

(404) 636-8400

<http://www.ashrae.org>

Noise and Vibration Control

- Murray, T.M., D.E. Allen, and E.B. Ungar. 1997. *Steel design guide series 11: Floor vibrations due to human activity*. American Institute of Steel Construction, Chicago.
- Persson-Wayne, K., S. Benton, H.G. Leventhall, and R. Rylander. 1997. Effects on performance and work quality due to low frequency ventilation noise. *Journal of Sound and Vibration* 205(4):467-474.
- Reynolds, D.D. and W.D. Bevirt. 1994. *Procedural standards for the measurement and assessment of sound and vibration*. National Environmental Balancing Bureau, Rockville, MD.
- Reynolds, D.D. and J.M. Bledsoe. 1989a. Sound attenuation of unlined and acoustically lined rectangular ducts. *ASHRAE Transactions* 95(1):90-95.
- Reynolds, D.D. and J.M. Bledsoe. 1989b. Sound attenuation of acoustically lined circular ducts and radiused elbows. *ASHRAE Transactions* 95(1):96-99.
- Reynolds, D.D. and J.M. Bledsoe. 1991. *Algorithms for HVAC acoustics*. ASHRAE.
- Schaffer, M.E. 2005. *A practical guide to noise and vibration control for HVAC systems*, 2nd ed. ASHRAE.
- Schultz, T.J. 1985. Relationship between sound power level and sound pressure level in dwellings and offices. *ASHRAE Transactions* 91(1A):124-153.
- Stabley, R.E. 2006. Sound ratings of water-cooled chillers—Sound pressure or power levels? In *Proceedings from Inter-Noise 2006*, Honolulu. Institute of Noise Control Engineering of the USA, Indianapolis, IN.
- Thompson, J.K. 1981. The room acoustics equation: Its limitation and potential. *ASHRAE Transactions* 87(2):1049-1057.
- Ver, I.L. 1978. A review of the attenuation of sound in straight lined and unlined ductwork of rectangular cross section. *ASHRAE Transactions* 84(1):122-149.
- Ver, I.L. 1982. A study to determine the noise generation and noise attenuation of lined and unlined duct fittings. *Report 5092*. Bolt, Beranek and Newman, Boston.
- Ver, I.L. 1983a. Noise generation and noise attenuation of duct fittings—A review: Part I (RP-265). *ASHRAE Transactions* 90(2A):354-382.
- Ver, I.L. 1983b. Noise generation and noise attenuation of duct fittings—A review: Part II (RP-265). *ASHRAE Transactions* 90(2A):383-390.
- Warnock, A.C.C. 1998. Transmission of sound from air terminal devices through ceiling systems. *ASHRAE Transactions* 104(1A):650-657.
- Wells, R.J. 1958. Acoustical plenum chambers. *Noise Control* (July).
- Woods Fan Division. 1973. *Design for sound*. English Electric Company.

BIBLIOGRAPHY

- ALA. 2001. *Guidelines for design and construction of hospital and health care facilities*. American Institute of Architects, Washington, D.C.
- ANSI. 2002. Guide for the evaluation of human exposure to whole body vibration. *Standard S3.18-2002*. American National Standards Institute, Washington, D.C.
- ANSI. 2002. Determination of sound power levels of noise sources using sound pressure—Precision method for reverberation rooms. *Standard S12.51-2002*. American National Standards Institute, Washington, D.C.
- ANSI. 1999. Determination of sound power levels of noise sources using sound pressure—Engineering methods in an essentially free field over a reflecting plane. *Standard S12.54-1999*. American National Standards Institute, Washington, D.C.
- AHRI. 2001. Performance and calibration of reference sound sources. *Standard 250-2001*. Air-Conditioning, Heating, and Refrigeration Institute, Arlington, VA.
- AHRI. 1995. Sound rating of outdoor unitary equipment. *Standard 270-1995*. Air-Conditioning, Heating, and Refrigeration Institute, Arlington, VA.

- AHRI. 1997. Application of sound rating levels of outdoor unitary equipment. *Standard 275-1997*. Air-Conditioning, Heating, and Refrigeration Institute, Arlington, VA.
- AHRI. 1995. Requirements for the qualification of reverberant rooms in the 63 Hz octave band. *Standard 280-1995*. Air-Conditioning, Heating, and Refrigeration Institute, Arlington, VA.
- AHRI. 2000. Sound rating and sound transmission loss of packaged terminal equipment. *Standard 300-2000*. Air-Conditioning, Heating, and Refrigeration Institute, Arlington, VA.
- AHRI. 2000. Sound rating of non-ducted indoor air-conditioning equipment. *Standard 350-2000*. Air-Conditioning, Heating, and Refrigeration Institute, Arlington, VA.
- AHRI. 2005. Method of measuring sound and vibration of refrigerant compressors. *Standard 530-2005*. Air-Conditioning, Heating, and Refrigeration Institute, Arlington, VA.
- AHRI. 1997. Assessing the impact of air-conditioning outdoor sound levels in the residential community. *Guideline L-1997*. Air-Conditioning, Heating, and Refrigeration Institute, Arlington, VA.
- ASHRAE. 2004. Ventilation for acceptable indoor air quality. *Standard 62.1-2004*.
- Cowan, J.P. 1994. *Handbook of environmental acoustics*. Van Nostrand Reinhold, New York.
- DEHS. 2005. *Eleventh annual report on carcinogens*. U.S. Department of Health and Human Services, Public Health Service, Washington, D.C.
- Environment Canada. 1994. Mineral fibres: Priority substances list assessment report. *Canadian Environmental Protection Act*, Ottawa.
- Morey, P.R. and C.M. Williams. 1991. Is porous insulation inside an HVAC system compatible with healthy building? ASHRAE IAQ Symposium.
- Reynolds, D.D. and W.D. Bevirt. 1989. *Sound and vibration design and analysis*. National Environmental Balancing Bureau, Rockville, MD.
- Sundbakken, M., L. Fende, and M.J. Crocker. 1981. Investigation of end reflection of coefficient accuracy problems with AMCA *Standard 300-67*. HL 81-16. Ray W. Herrick Laboratories, Purdue University, West Lafayette, IN.
- Schultz, T.J. 1972. *Community noise ratings*. Applied Science Publishers, London.
- SMACNA. 1990. *HVAC systems duct design*, 3rd ed. Sheet Metal and Air Conditioning Contractors' National Association, Vienna, VA.
- Ungar, E.E., D.H. Sturz, and C.H. Amick. 1990. Vibration control design of high technology facilities. *Sound and Vibration* 24(7):20-27.
- Ver, I.L. 1983. Prediction of sound transmission through duct walls: Break-out and pickup. *ASHRAE Transactions* 90(2A):391-413.

RESOURCES

- Acoustical Society of America (ASA).....www.asa.acp.org
- The Air-Conditioning, Heating, and Refrigeration Institute (AHRI)..... www.ahrinet.org
- Institute of Noise Control Engineers (INCE).....www.inceusa.org
- National Council of Acoustical Consultants (NCAC).....www.ncac.com
- National Environmental Balancing Bureau (NEBB)..... www.nebb.org
- Noise Pollution Clearinghouse..... www.nonoise.org
- North American Insulation Manufacturers Association (NAIMA)..... www.naima.org
- Testing, Adjusting and Balancing Bureau (TABB)..... www.tabbcertified.org
- Vibration Institute..... www.vibinst.org
- Sheet Metal and Air Conditioning Contractors' National Association (SMACNA)..... www.smacna.org

ID Fan Noise Research Study & Design Guide

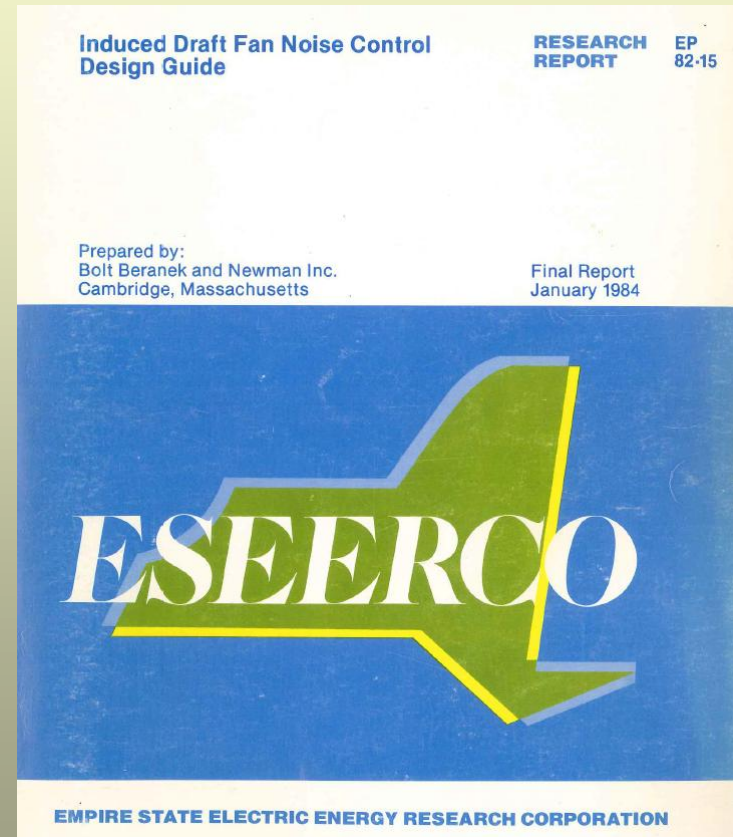
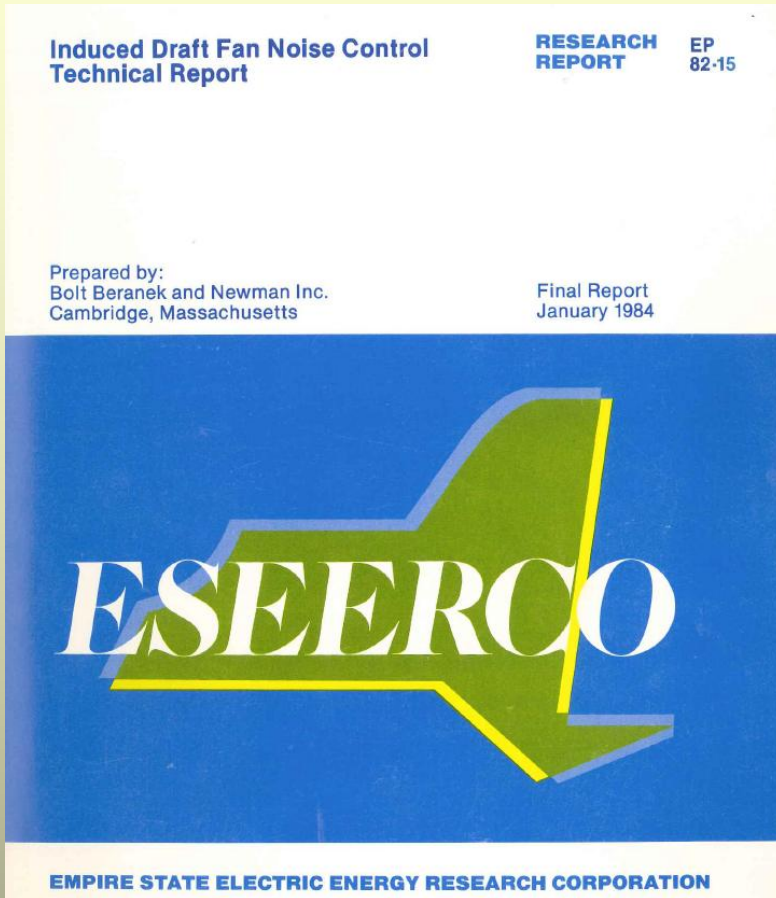



Tuned-Dissipative Muffler

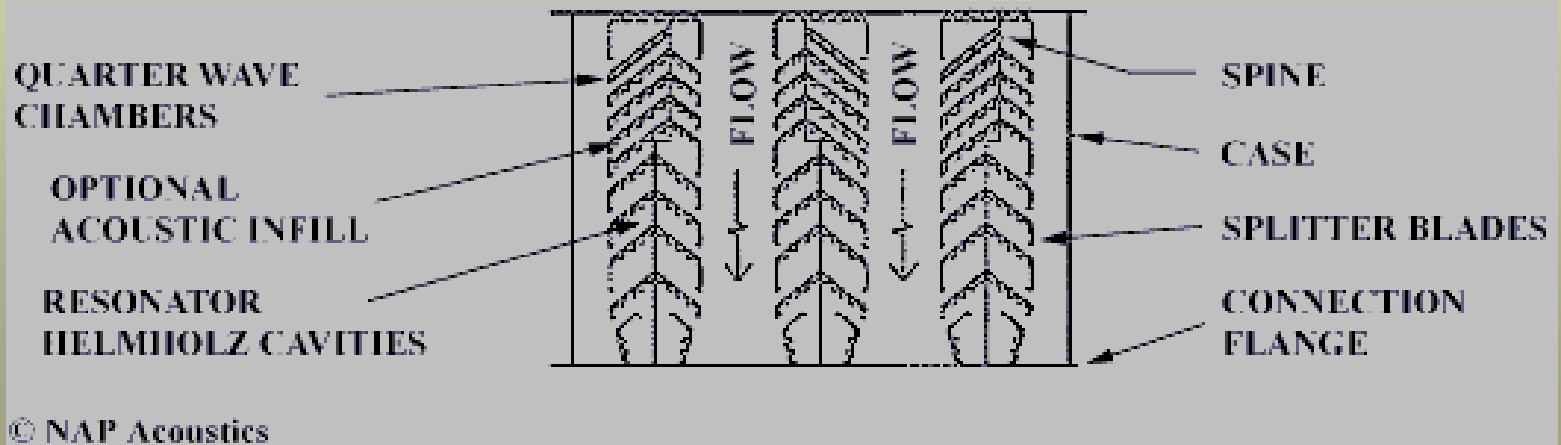

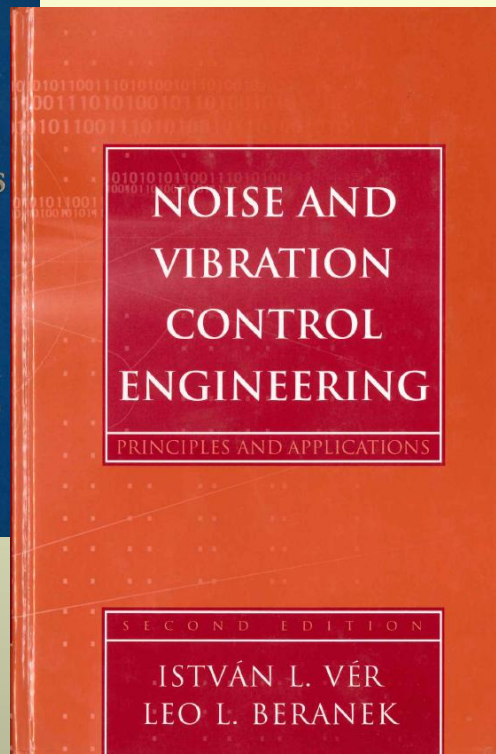
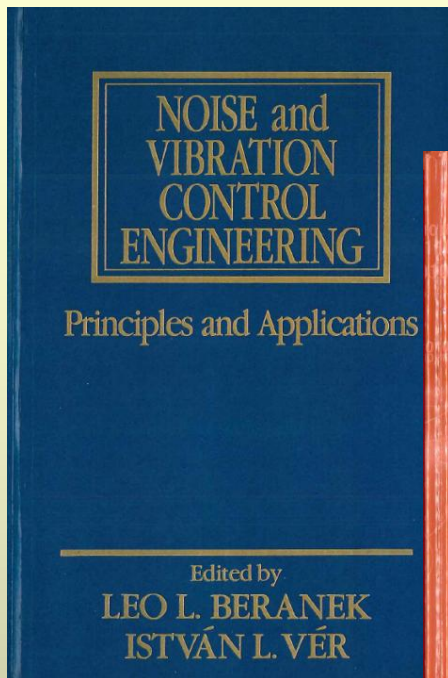

10. Sound Generation

István L. Vér

11. Interaction of Sound Waves with Solid Structures

István L. Vér

12. Enclosures, Cabins, and Wrappings

István L. Vér

" Some things get better with age, e.g. women, wine and pea soup. This is also true here. Each new book in this 'series' of books started by Leo Beranek in 1960 and continued with help from Istvan Ver has gotten better. They all maintain a depth that is not available in many of the other books available on noise control. This book has an excellent balance of practical and therefore useful guidelines and theoretical modeling with equations and data to support and permit easy extension of the guidelines to most of the situations faced by noise control engineers."

C. Burroughs review in Noise Control Engineering, July-August 2008



NoiseCon-16 Providence, RI



**Thank You
István**

Slides presented for Istvan Ver by Marika Ver.

















Slides presented for Istvan Ver by Nelson Kiang founder and former director of the famous Eaton-Peabody Laboratory jointly operated by Harvard, MIT, the Massachusetts Eye and Ear Infirmary and the Massachusetts General Hospital.

ISTVÁN L. VÉR (Professional Problem Solver)

Consultant in Acoustics, Noise and Vibration Control

Educational History:

Moving Rural to City

Secondary Schooling

B.S., Electrical Engineering, Technical University, Budapest, 1956

M.S., Electrical Engineering, Technical University, Aachen, Germany, 1959

Ph.D. (Dr.-Ing), Acoustics, Technical University, Munich, Germany, 1963

Massachusetts Eye and Ear Infirmary

243 Charles Street, Boston, Mass. 02114 Tel. 523-7900

Melville Chasin, *Chairman*
William H. Claffin, III, *President*
George M. Lovejoy, Jr., *Vice-President*
Eaton Catin, *Treasurer*
Mrs. John Lowell, *Secretary*

Charles T. Wood, *Director*
Charles D. J. Regan, M. D., *Acting Chief of Ophthalmology*
Harold F. Schubert, M. D., *Chief of Otolaryngology*

Eaton-Peabody Laboratory
January 9, 1974

Mr. Robert D. Bruce
Associate Division Director
Noise Control Engineering
Bolt Beranek and Newman Inc.
235 Wyman Street
Waltham, Massachusetts 02154

Dear Mr. Bruce:

Thank you for your letter of 31 December 1973. I first met István Vér in 1968 when he began work as the acoustical consultant on the new building for the Massachusetts Eye and Ear Infirmary. Our laboratory is jointly operated by the Massachusetts Eye and Ear Infirmary, the Massachusetts Institute of Technology, and Harvard Medical School for the purpose of studying hearing. The laboratory had to be moved out of the Massachusetts Eye and Ear Infirmary to temporary quarters at MIT until an enlarged laboratory could be constructed in the new building at the Infirmary. The physiological work of the laboratory requires elaborate experimental chambers requiring "sound proofing," vibration isolation and electrical shielding. István rapidly came to appreciate the complexity of the construction and soon had our complete confidence in his grasp of technical issues.

He not only participated in the design of our new laboratory facility in the Infirmary (still to be completed) but he did a superb job of helping to design our temporary chambers at MIT. I am enclosing a copy of a letter I wrote Bob Newman after the completion of our move to MIT. Since then we have found the acoustical design of our chambers here to be all that we asked for and eminently useful. The job was unusual but István was on top of the complications at all times. He has a good appreciation of the users' problems and of practical considerations. We continue to have the highest respect for his professional competence.

During the years since 1968, I have had many opportunities to observe István and have been impressed with his general intellectual capacity and his honesty as a person. I should be very surprised if he were not held in the highest regard by his colleagues and associates at BBN. Perhaps I should mention that several times in our relationship István, through no fault of his own, was placed in difficult situations requiring moral decisions.



The Massachusetts Eye and Ear Infirmary was established in 1824. It is an independent, voluntary, non-profit hospital that specializes in the treatment of diseases affecting the eye, ear, nose and throat.

Mr. Robert D. Bruce

- 2 -

January 9, 1974

In these situations he showed a fine appreciation of ethics and as a consequence has my personal trust. In other instances he has made choices that would have benefited BBN even when his personal gain might have been greater otherwise.

In summary, my opinion of István is high on both professional and personal grounds. Although the present rank for which he is being considered is a technical one, I should not overlook the possibility that he could serve the company at higher levels in the future.

Very sincerely yours,

Nelson Y. S. Kiang
Director
Eaton-Peabody Laboratory of Auditory Physiology

NYSK:gsr
Enclosure

Notable “Hungarians”

a sample from Paul Lendvai’s *“The Hungarians: A Thousand Years of Victory in Defeat”*
translated by Ann Major, Princeton University Press (2003)

Paul (Pal) Erdős	mathematician
John G. Kemény	mathematician
John (János) von Neuman	mathematician
Georg Pólya	mathematician
Leo Szilárd	physicist
Edward Teller	physicist
Eugene (Jenö) Wigner	physicist
Theodore von Kármán	rocket scientist
Georg von Békésy	acoustician
Georg von Hevesi	chemist
Gyögy Oláh	chemist
Albert von Szentgyörgy	biologist
Ernö Rubik	inventor
Andy Grove (András Gróf)	founder of Intel
Marcel Breuer	architect
Thomas C. Szaz	psychiatrist

Elie Wiesel	writer
Arthur Koestler	writer
George (György) Mikes	writer, humorist
Ferenc Molnar	writer, playwright
George (György) Tábory	playwright
József Pulitzer	journalist
Stephan Lorant	photojournalist
Gyula Halász	photographer
Béla Bartók	musician
Eugene Ormandy (Jenő Blau).	musician
George Szell	musician
Adolph Zukor	founder, Paramount Studios
William Fox	founder, Fox Studios
Michael Curtiz (Mihály Kertész) ..	film director
Sir Alexander Korda (László Sándor Kellner) ..	film director & producer
Gabor sisters (Eva, Magda, Zsa Zsa) ...	actresses
Béla Lugosi	actor
Paul Lukas	actor
Ilona Massey	actress
Tony Curtis (Bernie Schwartz)	actor
Moholy-Nagy	designer
Lord Nicholas Káldor	economist
George Pataki	politician
Nicolas Sarkozy	politician
George (György) Soros	philanthropist
many chess, bridge, sports players	

Possible Factors in Producing Istváns

1. Genetics
2. Language
3. Historical Contacts
4. Schooling
5. Survivingness
6. Diaspora
7. All of these...plus ?

A Cultural History of Physics

Károly Simonyi



 CRC Press
Taylor & Francis Group
AN A K PETERS BOOK

2012

Figure 75. The European Union in Eastern Europe in 2013



Source: European Union website (www.europa.eu)

from "Eastern Europe" by Tomek Jankowski (2013)

Einstein–Szilárd letter

From Wikipedia, the free encyclopedia

The **Einstein–Szilárd letter** was a letter written by Leó Szilárd and signed by Albert Einstein that was sent to the United States President Franklin D. Roosevelt on August 2, 1939.

Written by Szilárd in consultation with fellow Hungarian physicists Edward Teller and Eugene Wigner, the letter warned that Germany might develop atomic bombs and suggested that the United States should start its own nuclear program. It prompted action by Roosevelt, which eventually resulted in the Manhattan Project developing the first atomic bombs.

SELECTIONS
FROM
LIVES
OF
THE ENGINEERS

WITH
AN ACCOUNT OF THEIR PRINCIPAL WORKS

BY SAMUEL SMILES

edited and with an introduction

BY THOMAS PARKE HUGHES

"Bid Harbours open, Public Ways extend;
Bid Temples, worthier of God, ascend;
Bid the broad Arch the dang'rous flood contain,
The Mole projected, break the roaring main;
Back to his bounds their subject sea command,
And roll obedient rivers through the land.
These honours, Peace to happy Britain brings;
These are imperial works, and worthy kings."

POPE.

WITH PORTRAITS AND NUMEROUS ILLUSTRATIONS.

1966

THE M.I.T. PRESS
MASSACHUSETTS INSTITUTE OF TECHNOLOGY
CAMBRIDGE, MASSACHUSETTS, AND LONDON, ENGLAND